

INSTRUCTION MANUAL FOR PLASMA CUTTER



IMPORTANT: BEFORE STARTING THE EQUIPMENT, READ THE CONTENTS OF THIS MANUAL, WHICH MUST BE STORED IN A PLACE FAMILIAR TO ALL USERS FOR THE ENTIRE OPERATIVE LIFE-SPAN OF THE MACHINE.
THIS EQUIPMENT MUST BE USED SOLELY FOR WELDING OPERATIONS.

1 SAFETY PRECAUTIONS



WELDING AND ARC CUTTING CAN BE HARMFUL TO YOURSELF AND OTHERS.

The user must therefore be educated against the hazards, summarized below, deriving from welding operations. For more detailed information, order the manual code 3.300.758

ELECTRIC SHOCK - May be fatal.



- Install and earth the welding machine according to the applicable regulations.
- Do not touch live electrical parts or electrodes with bare skin, gloves or wet clothing.
- Isolate yourselves from both the earth and the workpiece.
- Make sure your working position is safe.

FUMES AND GASES - May be hazardous to your health.



- Keep your head away from fumes.
- Work in the presence of adequate ventilation, and use ventilators around the arc to prevent gases from forming in the work area.

ARC RAYS - May injure the eyes and burn the skin.



- Protect your eyes with welding masks fitted with filtered lenses, and protect your body with appropriate safety garments.
- Protect others by installing adequate shields or curtains.

RISK OF FIRE AND BURNS



- Sparks (sprays) may cause fires and burn the skin; you should therefore make sure there are no flammable materials in the area, and wear appropriate protective garments.

NOISE



This machine does not directly produce noise exceeding 80dB. The plasma cutting/welding procedure may produce noise levels beyond said limit; users must therefore implement all precautions required by law.

PACEMAKERS

· The magnetic fields created by high currents may affect the operation of pacemakers. Wearers of vital electronic equipment (pacemakers) should consult their physician before beginning any arc welding, cutting, gouging or spot welding operations.

EXPLOSIONS



· Do not weld in the vicinity of containers under pressure, or in the presence of explosive dust, gases or fumes. · All cylinders and pressure regulators used in welding operations should be handled with care.

ELECTROMAGNETIC COMPATIBILITY

This machine is manufactured in compliance with the instructions contained in the harmonized standard EN50199, **and must be used solely for professional purposes in an industrial environment. There may be potential difficulties in ensuring electromagnetic compatibility in non-industrial environments.**

IN CASE OF MALFUNCTIONS, REQUEST ASSISTANCE FROM QUALIFIED PERSONNEL.

2 INSTALLATION

2.1 TORCH ASSEMBLY (Fig. 1)

Insert the torch fitting into the guard **R**, then onto the fitting **P**, firmly tightening the ring-nut to avoid air leaks that could damage or interfere with smooth operation of the torch.

Do not dent the current pin or bend the pegs of the torch fitting. A dented pin may not disconnect, while a bent peg does not allow proper insertion onto the fixed fitting **P**, thereby preventing the machine from working.

Use the screws provided to fasten the guard **R** on to the panel.

2.2 DESCRIPTION OF DEVICES ON THE MACHINE

- A) Power cord
- B) Compressed air fitting (1/4" female gas thread)
- C) Mains power switch
- E) Pressure regulator knob
- F) Pressure gauge
- G) Thermostat LED
- H) Grounding clamp
- I) Water trap
- L) Low air pressure LED
- M) Cutting current regulator knob
- P) Torch fitting
- R) Safety guard
- S) Blocked LED; lights when hazardous conditions arise.
- T) Push-button to activate and deactivate the "SELF-RESTART PILOT" function.
- U) Plasma torch.
- V) Mains power led.

2.3 SAFETY DEVICES

This system comes equipped with the following safety devices:

Overload cutout:

 1) To avoid overloads. It is evidenced by the **G** led continuously on (see fig.1).

Pneumatic:

 Located on the torch inlet to prevent low air pressure. The LED **L** lights when tripped (see fig.1).

The blinking L led means that the pressure has temporarily gone below 3.2 ÷ 3.5 bar.

Electrical:

Located on the torch body, to prevent hazardous voltages from occurring on the torch when, swirl ring, electrode or nozzle holder are replaced;

• **Do not remove or short-circuit the safety devices.**

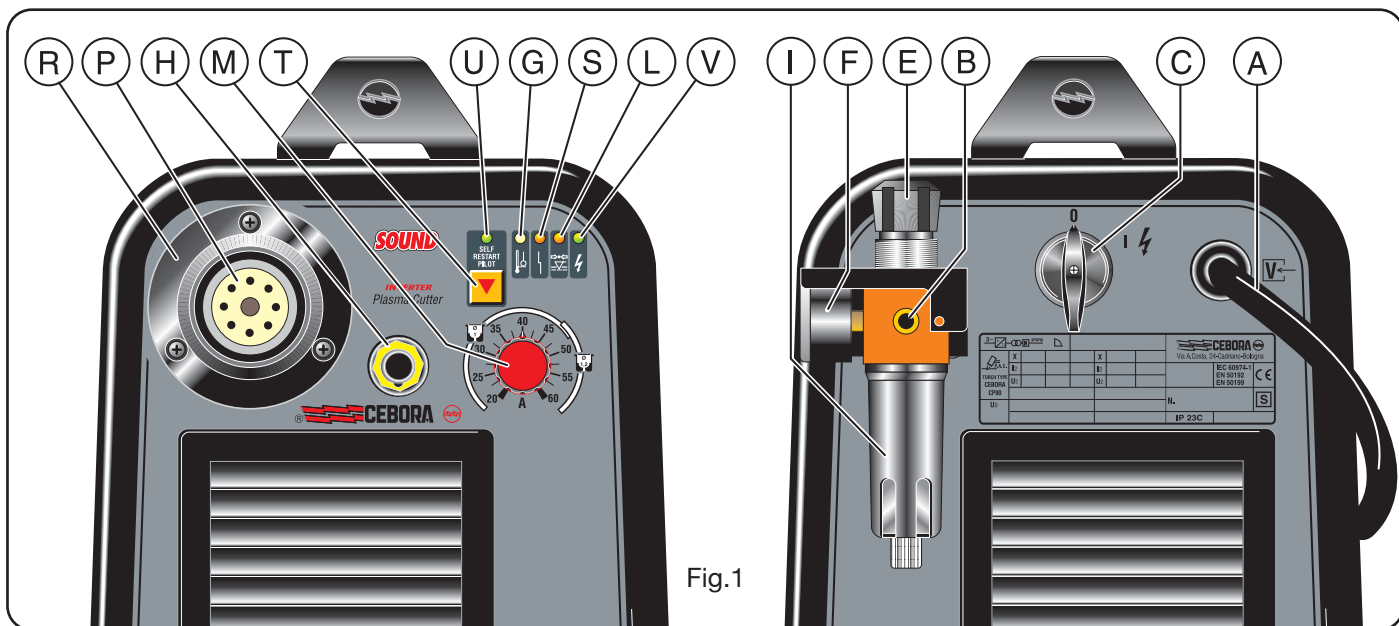

Fig.1

- Use only original spare parts.
- Always replace any damaged parts of the machine with original materials.
- Do not run the machine without its housings. This would be dangerous to the operator and anyone else in the work area, and would prevent the machine from being cooled properly.

2.4 EXPLANATION OF TECHNICAL SPECIFICATIONS

IEC 60974.1 The equipment is built according to these EN 50192 standards.

IEC 60974-7

N°. Serial number.
Must be indicated on any type of request regarding the device.

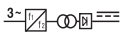
 Three-phase static transformer-rectifier frequency converter.

 Downslope.

 Suitable for plasma cutting.

TORCH TYPE Type of torch that may be used with this machine to form a safe system.

U_0 . Secondary open-circuit voltage.

X. Duty cycle percentage.

The duty cycle expresses the percentage of 10 minutes during which the welding machine may run at a certain current I_2 and voltage U_2 without overheating.

I_2 . Cutting current.

Art. 355: 60A @ 208/220/230/400/440V

Art. 357: a) 100A @ 400/440V

b) 80A @ 208/220/230V

U_2 Secondary conventional voltage with welding current I_2 . This voltage depends on the distance between the contact tip and the workpiece.

If this distance increases, the cutting voltage also increases and the duty cycle may decrease.

X%

U_1 . Rated supply voltage for 208/220/230V - 400/440V with automatic voltage change.

3~ 50/60Hz 50- or 60-Hz three-phase power supply
 I_1 Max Max. absorbed current at the corresponding current I_2 and voltage U_2 .

I_1 eff This is the maximum value of the actual current absorbed, considering the duty cycle. This value usually corresponds to the capacity of the fuse (delayed type) to be used as a protection for the equipment.

IP23 C. Protection rating for the housing. Grade **3** as the second digit means that this equipment is suitable for use outdoors in the rain. The additional letter **C** means that the equipment is protected against access to the live parts of the power circuit by a tool (diameter 2.5 mm).

S. Suitable for use in high-risk environments.

NOTES: The machine has also been designed for use in environments with a pollution rating of 3. (See IEC 664).

2.5 START-UP

The machine must be installed by qualified personnel. All connections must be made in compliance with current safety standards and full observance of safety regulations (see CEI 26-23 - IEC TS 62081).

Connect the air supply to the fitting **B**.

If the air supply comes from a pressure regulator of a compressor or centralized system, the regulator must be set to an output pressure of no more than 8 bar (0.8 Mpa). If the air supply comes from a compressed air cylinder, the cylinder must be equipped with a pressure regulator. **Never connect a compressed air cylinder directly to the regulator on the machine! The pressure could exceed the capacity of the regulator, which might explode!**

Connect the power cord **A**: the yellow-green cable wire must be connected to an efficient grounding socket on the system. The remaining wires must be connected to the power supply line by means of a switch placed as close as possible to the cutting area, to allow it to be shut off quickly in case of emergency.

The capacity of the cut-out switch or fuses installed in series with the switch must be equal to the current $I_{1\text{eff}}$ absorbed by the machine.

The absorbed current $I_{1\text{eff}}$ may be determined by reading the technical specifications shown on the machine under the available supply voltage U_1 .

Any extension cords must be sized appropriately for the absorbed current $I_{1\text{max}}$.

3 USE

Make sure the trigger has not been pressed.

Turn the machine on using the switch **C**. The warning lamp **V** will light to indicate that the machine is on.

Press the torch trigger briefly to open the flow of compressed air. Under this condition set the pressure shown by the pressure gauge **F**, at 4,7 bar (0.47 MPa) for Art. 355 and 5 bar (0,5 MPa) for Art. 357 by means of the reducer knob **E**, and then lock the knob by pushing it down. Connect the grounding clamp to the workpiece.

The cutting circuit must not be deliberately placed in direct or indirect contact with the protective wire except in the workpiece.

If the workpiece is deliberately grounded using the protective conductor, the connection must be as direct as possible and use a wire of at least the same size as the cutting current return wire, and connected to the workpiece at the same point as the return wire using the return wire clamp or a second grounding clamp placed in the immediate vicinity. Every precaution must be taken to avoid stray currents.

Use the knob **M** to select the cutting current.

Art. 355:

use nozzle \varnothing 1 up to 45 A and 1,2 from 45 to 60A.

With nozzle \varnothing 1 a contact cutting can be made; the recommended voltage should not be exceeded to avoid damaging the nozzle port because this would produce a very poor quality cut.

With nozzle \varnothing 1,2 and 45 to 60 A currents use the two faces spacer Art. 1404.

Art 357:

use nozzle \varnothing 1,1 up to 45 and 1,3 from 20 to 100 A.

With nozzle \varnothing 1,1 a contact cutting can be made; the recommended voltage should not be exceeded to avoid damaging the nozzle port because this would produce a very poor quality cut.

With nozzle \varnothing 1,3 and 45 to 100 A currents use the two faces spacer Art. 1408 or spring Art.1386.

Make sure that the grounding clamp and workpiece have a good electrical contact, especially with painted, oxidized or insulated sheet metal.

Do not connect the grounding clamp to the part of the material that is to be removed.

Press the torch trigger to strike the pilot arc.

If cutting does not begin within 2 seconds, the pilot arc goes out; press the trigger again to re-strike it.

Hold the torch upright while cutting.

When you have finished cutting and released the trigger, air will continue to leave the torch for approximately 100 seconds to allow the torch to cool down.

It is best not to turn the machine off until this cool-down period is complete.

Should you need to make holes or begin cutting from the

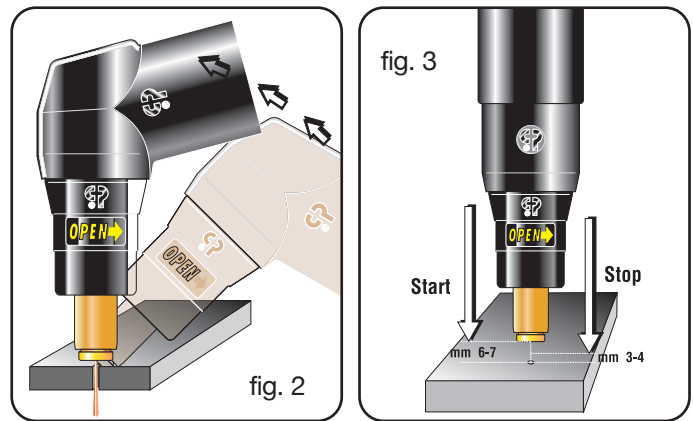

center of the workpiece, you must hold the torch at an angle and slowly straighten it so that the nozzle does not spray molten metal (see fig. 2). This must be done when making holes in pieces more than 3 mm thick.

During automatic operation (see fig. 3), hold the nozzle 6/7 mm away from the workpiece. After the hole has been made, move it to a distance of approximately 3/4 mm.

For thicknesses greater than 6/8 mm, the material must be perforated before cutting.

When making circular cuts, we recommend using the special compass available upon request. It is important to remember that use of the compass may make it necessary to use the starting technique described above (fig.2). Do not keep the pilot arc lit in the air when not needed, to avoid unnecessary consumption of the electrode, swirl ring or nozzle.

Turn the machine off when the task is completed.

To cut perforated or grid metal, activate the "Pilot self restart" function using the push-button P (LED O lit).

When you have finished cutting, holding this push-button down will cause the pilot arc to restart automatically.

Use this function only if necessary to avoid unnecessary wear on the electrode and nozzle.

4 CUTTING ERRORS

4.1 INSUFFICIENT PENETRATION

This error may be caused by the following:

- high speed. Always make sure that the arc fully penetrates the workpiece and is never held at a forward angle of more than 10 -15°. This will avoid incorrect consumption of the nozzle and burns to the nozzle holder.
- Excessively thick workpiece (see cutting speed diagrams, fig. 4)
- Grounding clamp not in good electrical contact with the workpiece.
- Worn nozzle and electrode.
- Cutting current too low.

NOTE: When the arc does not penetrate, the molten metal scraps obstruct the nozzle.

4.2 THE CUTTING ARC GOES OFF

This error may be caused by:

- worn nozzle, electrode or swirl ring
- air pressure too high
- supply voltage too low

4.3 SLANTED CUT

If the cut appears slanted, turn the machine off and replace the nozzle.

When the cutting current is above 45 A, prevent the nozzle from coming into electrical contact with the workpiece (even through scraps of molten metal), this condition causes rapid and at times instantaneous destruction of the nozzle hole, leading to poor quality cutting.

4.4 EXCESSIVE WEAR ON CONSUMABLEE PARTS

This problem may be caused by:

- air pressure too low compared to the recommended level.
- excessive burns on the end of the nozzle holder.

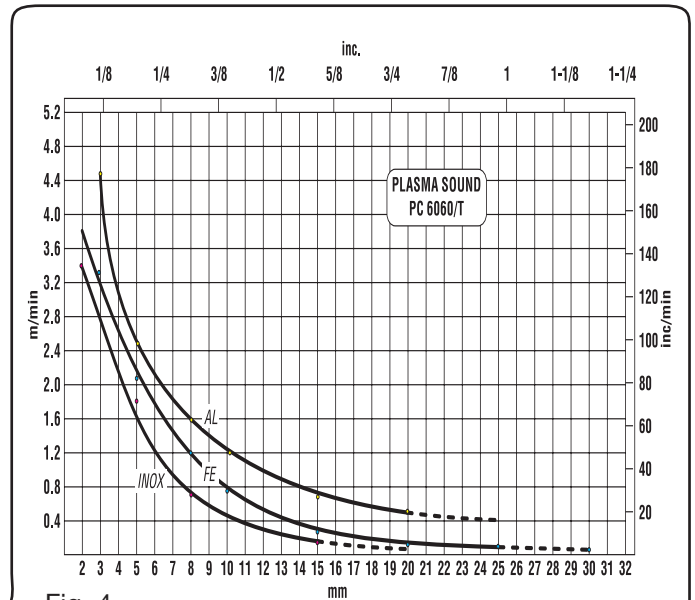
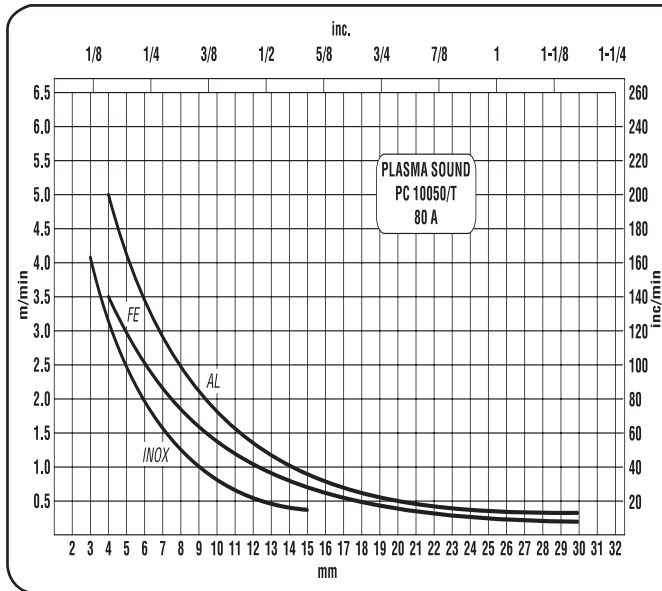
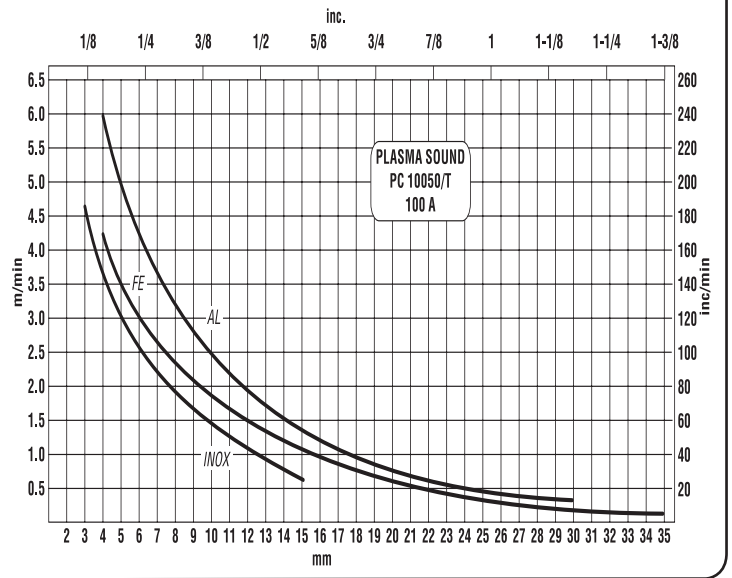

Fig. 4



5 HELPFUL HINTS

- If the system air contains considerable amounts of moisture and oil, it is best to use a drying filter to avoid excessive oxidation and wear on consumer parts, damage to the torch and a reduction in the speed and quality of the cutting.
- The impurities in the air encourage oxidation of the electrode and nozzle, and may make it difficult to strike the pilot arc. If this occurs, use fine sandpaper to clean the end of the electrode and the interior of the nozzle.
- Make sure that the new electrode and nozzle to be mounted are thoroughly clean and degreased.
- Always use original spare parts to avoid damaging the torch.**

6 MAINTENANCE

Always cut off the power supply to the machine before any operation, which must always be carried out by qualified personnel.

6.1 GENERATOR MAINTENANCE

In the case of maintenance inside the machine, make sure that the switch **C** is in position "O" and that the **power cord is disconnected from the mains.**

Also make sure that there is no voltage at the ends of the IGBT group capacitors.

Even though the machine is equipped with an automatic condensation drainage device that is tripped each time the air supply is closed, it is good practice to periodically make sure that there is no condensation accumulated in the water trap **I** (fig.1).

It is also necessary to periodically clean the interior of the machine from the accumulated metal dust, using compressed air.

6.1.1 Troubleshooting (Art. 356 only)

The LED **S** lights when the following conditions occur:

LED S	CONDITION	SOLUTION
Steadily lit	Upon equipment start-up	Wait 5 sec
Steadily lit	Button pressed during equipment start-up	Release the button
Steadily lit	Missing safety protection R	Mount the protection
Steadily lit	Incorrect IGBT drive voltage	Contact technical service
Steadily lit	Reed contact closed during equipment start-up	Contact technical service
Steadily lit	Supply voltage too low	Check the supply voltage
Steadily lit	Phase missing in the power supply line	Check the power supply line. Note: in some situations a missing phase does not cause the LED S to light, therefore you should always check the power supply line in the case of malfunction
Flashing lit	Short-circuit between electrode and nozzle during equipment start-up or during cutting	Replace the electrode and gas nozzle, and diffuser if necessary

6.2 TORCH MAINTENANCE

In reference to Fig. 7, the parts subject to wear are the electrode **A**, the swirl ring **B** and the nozzle **C**; these must be replaced after first unscrewing the gas nozzle holder **D**. The electrode **A** must be replaced when it has a crater in the center approximately 1.5 mm deep.

CAUTION: do not use sudden force to unscrew the electrode; work gradually to release the thread. The new electrode must be screwed into the seat and fastened in place without tightening fully.

The nozzle **C** must be replaced when the central hole is damaged or wider than that of a new part. Delays in replacing the electrode or nozzle will cause the parts to overheat, and jeopardize the life-span of the swirl ring **B**. Make sure that the gas nozzle holder **D** is firmly tightened after replacement.

CAUTION: Screw the gas nozzle holder **D** onto the torch body only with the electrode **A**, swirl ring **B** and nozzle **C** mounted.

If any of these parts are missing, this will interfere with smooth operation of the machine and, especially, jeopardize operator safety.

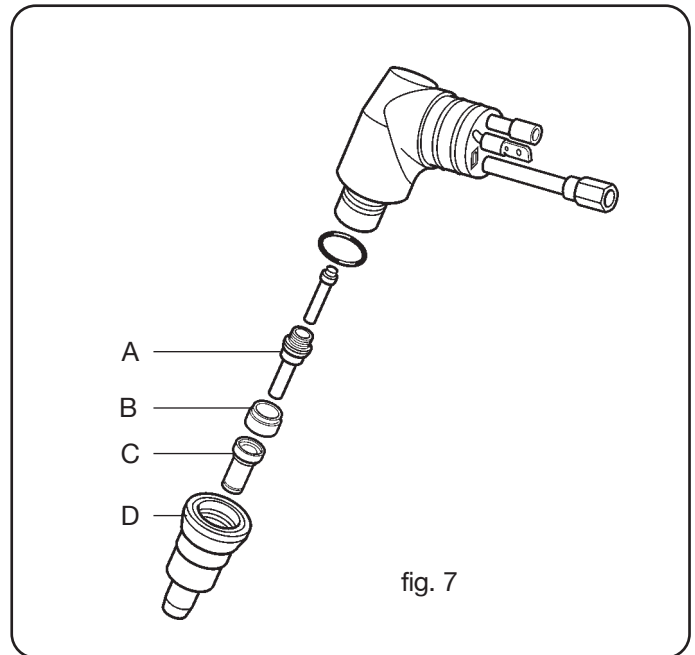

fig. 7

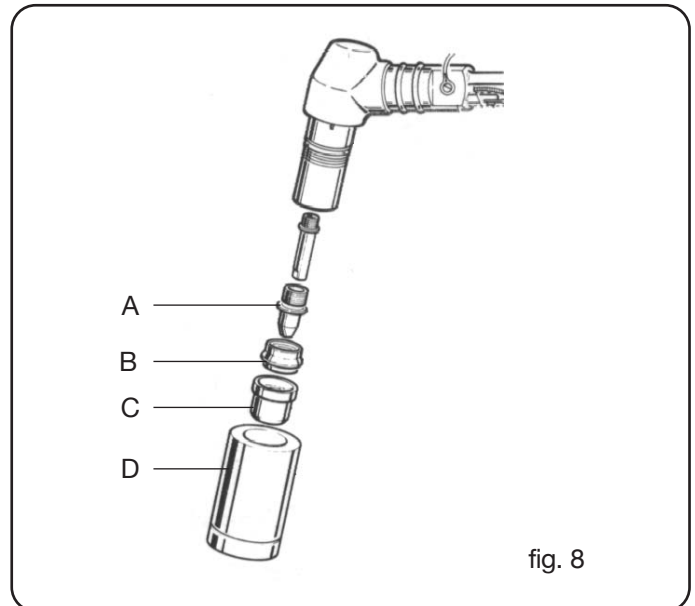

fig. 8

6.3 PRECAUTIONS AFTER REPAIRS.

After making repairs, take care to organize the wiring so that there is secure insulation between the primary and secondary sides of the machine. Do not allow the wires to come into contact with moving parts or those that heat up during operation. Reassemble all clamps as they were on the original machine, to prevent a connection from occurring between the primary and secondary circuits should a wire accidentally break or be disconnected.

Also mount the screws with geared washers as on the original machine.