



Burs Catalogue

Hartmetallfrässtifte

Fraises limes

Fresas rotativas de
metal duro

Contents

Inhalte / Sommaire / Índice

Introduction Einleitung / Introduction / Introducción	4 - 5
Application Data / Anwendungsgebiete / Données relatives aux applications / Datos de aplicaciones	6 - 11
Safety Symbols Sicherheitssymbole / Symboles de sécurité / Símbolos de seguridad	12
Tungsten carbide burs / Hartmetallfrässtifte / Fraises lime en carbure de tungstène / Fresas rotativas de metal duro	13 - 47

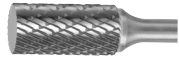
	Cylinder Zylinderform Cylindrique Cilindro	RAPIDE® Coated burs - cylinder RAPIDE® Zylinderform RAPIDE® Cylindrique RAPIDE® Cilindro	14 - 15
--	--	--	---------

	Cylinder - with end cut Zylinderform - Mit Stirnverzahnung Cylindre - coupe en bout Cilindro - con dentado frontal	RAPIDE® Cylinder - with end cut RAPIDE® Zylinderform - Mit Stirnverzahnung RAPIDE® Cylindre - coupe en bout RAPIDE® Cilindro - con dentado frontal	16 - 17
--	--	--	---------

	Ball nosed cylinder Walzenrundform Cylindrique bout rond Cilindro esférico	RAPIDE® Ball nosed cylinder RAPIDE® Walzenrundform RAPIDE® Cylindrique bout rond RAPIDE® Cilindro esférico	18 - 19
--	--	--	---------

	Ball Kugelform Sphérique Esférica	RAPIDE® Ball RAPIDE® Kugelform RAPIDE® Sphérique RAPIDE® Esférica	20 - 21
--	---	---	---------

	Oval Tropfenform Ovale Gota	RAPIDE® Oval RAPIDE® Tropfenform RAPIDE® Ovale RAPIDE® Gota	22 - 23
--	---	---	---------



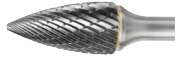





	Ball nosed tree Rundbogenform Ogive bout rond Ojival esférica	RAPIDE® Ball nosed tree RAPIDE® Rundbogenform RAPIDE® Ogive bout rond RAPIDE® Ojival esférica	24 - 25
--	---	---	---------

	Tree Spitzbogenform Ogive Ojival	RAPIDE® Tree RAPIDE® Spitzbogenform RAPIDE® Ogive RAPIDE® Ojival	26 - 27
--	--	--	---------

	Flame Flammenform Flamme Llama	RAPIDE® Flame RAPIDE® Flammenform RAPIDE® Flamme RAPIDE® Llama	28 - 29
--	--	--	---------

	Countersink 60° Kegelsenkform 60° Cône 60° Cono - en grados 60°	RAPIDE® Countersink 60° RAPIDE® Kegelsenkform 60° RAPIDE® Cône 60° RAPIDE® Cono - en grados 60°	30 - 31
--	---	---	---------

	Countersink 90° Kegelsenkform 90° Cône 90° Cono - en grados 90°	RAPIDE® Countersink 90° RAPIDE® Kegelsenkform 90° RAPIDE® Cône 90° RAPIDE® Cono - en grados 90°	32 - 33
--	---	---	---------

<p>Ball nosed cone Rundkegelform Conique bout rond Cilindro cono esférico</p>	<p>RAPIDE® Ball nosed cone RAPIDE® Rundkegelform RAPIDE® Conique bout rond RAPIDE® Cilindro cono esférico</p>	<p>34 - 35</p>	
<p>Cone Spitzkegelform Conique Cono</p>	<p>RAPIDE® Cone RAPIDE® Spitzkegelform RAPIDE® Conique RAPIDE® Cono</p>	<p>36 - 37</p>	
<p>Inverted cone Winkelfrässtifte Cône inversé Cono invertido sin dentado frontal</p>	<p>RAPIDE® Inverted cone RAPIDE® Winkelfrässtifte RAPIDE® Cône inversé RAPIDE® Cono invertido sin dentado frontal</p>	<p>38 - 39</p>	
<p>Rim Scheibenform Fraise disque Disco</p>	<p>RAPIDE® Rim RAPIDE® Scheibenform RAPIDE® Fraise disque RAPIDE® Disco</p>	<p>40 - 41</p>	
<p>Miniature Burs / Hartmetall Kleinfrässtifte / Mini fraises carbure / Fresas rotativas de metal duro - miniatura</p>		<p>42 - 43</p>	
<p>Extra long / Extra lang / Extra longue / Serie extra larga</p>		<p>44 - 46</p>	
<p>Extra long Extra lang Extra longue Serie extra larga</p>	<p>RAPIDE® Extra long RAPIDE® Extra lang RAPIDE® Extra longue RAPIDE® Serie extra larga</p>		
<p>Alloy Specific Range / Spéciale alliages</p>		<p>49 - 54</p>	
<p>Inox Range / Inox Serie / Gamme Inox / Gama Inoxidable</p>		<p>55 - 61</p>	
<p>Inox Range Inox Serie Gamme Inox Gama Inoxidable</p>			
<p>Steel Range / Steel Serie / Gamme Acier / gama de acero</p>		<p>63 - 69</p>	
<p>Steel Range Steel Serie Gamme Acier Gama de acero</p>			
<p>Base Metal Range / Grundmetallfrässtifte / Métal de base</p>		<p>71 - 75</p>	
<p>Fiberglass Routers / Konturenfräser / Fraises à détourer pour fibre de verre / Fresas para fibra de vidrio</p>		<p>77 - 79</p>	
<p>Fiberglass Routers Konturenfräser Fraises à détourer pour fibre de verre Fresas para fibra de vidrio</p>			
<p>Bur Sets / Frässtift-Sets / Kits de fraises / Juegos de fresas rotativas</p>		<p>81 - 90</p>	
<p>Bur Sets Frässtift-Sets Kits de fraises Juegos de fresas rotativas</p>			

Introduction

Einleitung / Introduction / Introducción



We are committed to being the leading manufacturer and supplier of carbide burs in the world. Through continuous development of new and innovative products and services, using state-of-the-art technology and skilled, motivated people, we strive to provide you with cost-effective solutions and the support that you need to increase your competitive advantage.



Wir sind einer der weltweit führenden Hersteller und Lieferanten von besonderen Schleifscheiben und Hartmetallfrässtiften. Basierend auf der kontinuierlichen Entwicklung neuer und innovativer Produkte und Dienstleistungen durch motivierte, hoch qualifizierte Mitarbeiter und durch Anwendung modernster Technologien können wir Ihnen stets kosteneffektive Lösungen und Dienstleistungen bieten, die zum Ausbau Ihrer Wettbewerbsfähigkeit beitragen.



Technology

In-house designed, fully automated equipment for cost-effective manufacture.

Technologie

Im eigenen Hause konstruierte und voll automatisierte Anlagen für einen kosteneffektiven Herstellungsprozess.

La technologie

Un matériel entièrement automatisé conçu par notre compagnie, pour des opérations de fabrication rentables.

Tecnología

Equipos totalmente automatizados, diseñados internamente, para una fabricación económicamente eficaz.

Innovation

Continuous investment in customer and application driven development of new products, giving you effective solutions.

Innovation

Effektive Lösungen für Sie durch kontinuierliche Investition in die kunden- und anwendungsspezifische Entwicklung neuer Produkte.

l'innovation

Nous investissons continuellement dans le développement de nouveaux produits – un développement guidé par nos clients et par les applications nécessaires pour vous offrir des solutions efficaces.

Innovación

Inversión permanente en clientes y desarrollo de nuevos productos que le proporcionan soluciones eficaces.



Nous avons la volonté d'être un fabricant mondial de premier plan et un fournisseur d'abrasifs, et de fraises-limes carbure. Par le développement continu de produits et services inédits et novateurs, faisant appel à une technologie de pointe et à un personnel qualifié et motivé, nous nous efforçons de vous fournir des solutions rentables et de vous offrir le soutien dont vous avez besoin pour augmenter votre avance concurrentielle.



Nosotros estamos comprometidos a ser el fabricante y proveedor líder en abrasivos especiales, y fresas rotativas. Por medio del desarrollo continuo de productos y servicios nuevos e innovadores, utilizando la tecnología más reciente y personal entrenado y motivado, nos esforzamos para suministrarle soluciones económicamente eficaces y el apoyo que Usted necesita para aumentar su ventaja frente a la competencia.



Support

Technical, sales and customer service teams backed up with large product stocks all provide exceptional service.

Dienstleistung

Teams für Technik, Verkauf und Kundendienst sowie umfangreiche Produktlagerbestände gewährleisten einen ausgezeichneten Service.

Le soutien

Nos équipes techniques, commerciales et d'assistance à la clientèle s'appuient sur de vastes stocks de produits pour vous offrir un service exceptionnel.

Apoyo

Nuestros equipos técnicos, de ventas y de servicio a clientes, junto con las existencias de las almacenes, dan un servicio excepcional.

People

Professional, friendly staff throughout the world create the relationships you need.

Mitarbeiter

Unsere professionellen und freundlichen Angestellten sorgen weltweit für bedarfsgerechte Kundenbeziehungen.

Le personnel

Dans le monde entier, le professionnalisme et l'amabilité de notre personnel vous font bénéficier d'un service sur mesure.

El equipo

Un personal profesional y amistoso crea las relaciones de negocios que usted necesita en todo el mundo.

Application Data

Anwendungsgebiete / Données relatives aux applications / Datos de aplicaciones

Technical data

Technische Daten
Données techniques
Datos técnicos



Technical data

	Materials	Materialien	Matières	Materiales
1a	Steel	Stahl	Acier	Acero
1b	Hard steels	gehärteter Stahl	Acier trempé	Acero cementado
2	Stainless steel	Edelstahl	Acier inoxydable	Acero inoxidable
3	Cast iron	Gußeisen	Fonte	Hierro fundido
4	Titanium	Titan	Titane	Titanio
5	Nickel	Nickel	Nickel	Níquel
6	Copper / Copper alloys	Kupfer / Kupferlegierungen	Cuivre Alliages de cuivre	Cobre / Aleaciones de cobre
7	Aluminium	Aluminium	Aluminium	Aluminio
8	Plastics	Kunststoff	Plastiques	Plásticos
9	Cement	Cermet	Cerment	Cermet

Guide to running speeds

mat nr. MAX RPM	3mm / 0.125" 90,000	6mm / 0.250" 50,000	10mm / 0.375" 40,000	12mm / 0.500" 35,000	16mm / 0.625" 25,000
1a	60,000 - 80,000	35,000 - 45,000	22,500 - 35,000	20,500 - 30,000	15,000 - 20,000
1b	60,000 - 80,000	30,000 - 45,000	19,000 - 30,000	15,000 - 22,500	12,000 - 18,000
2	60,000 - 80,000	30,000 - 45,000	19,000 - 30,000	15,000 - 22,500	12,000 - 18,000
3	45,000 - 80,000	22,500 - 45,000	15,000 - 35,000	11,000 - 30,000	9,000 - 20,000
4	60,000 - 80,000	30,000 - 45,000	19,000 - 30,000	15,000 - 22,500	12,000 - 18,000
5	60,000 - 80,000	30,000 - 45,000	19,000 - 30,000	15,000 - 22,500	12,000 - 18,000
6	45,000 - 80,000	22,500 - 45,000	15,000 - 35,000	11,000 - 30,000	9,000 - 20,000
7	30,000 - 80,000	15,000 - 45,000	10,000 - 35,000	7,000 - 30,000	6,000 - 20,000
8	30,000 - 80,000	15,000 - 45,000	10,000 - 35,000	7,000 - 30,000	6,000 - 20,000
9	60,000 - 80,000	30,000 - 45,000	19,000 - 30,000	15,000 - 22,500	12,000 - 18,000

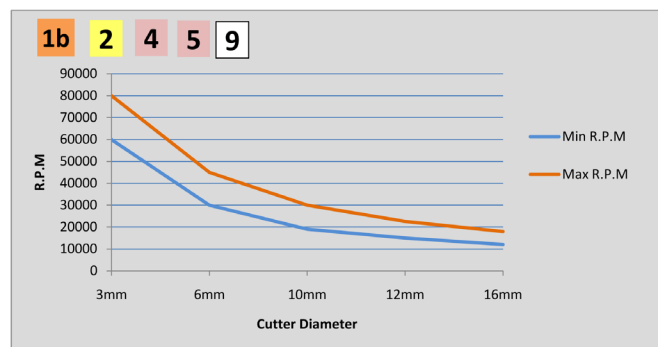
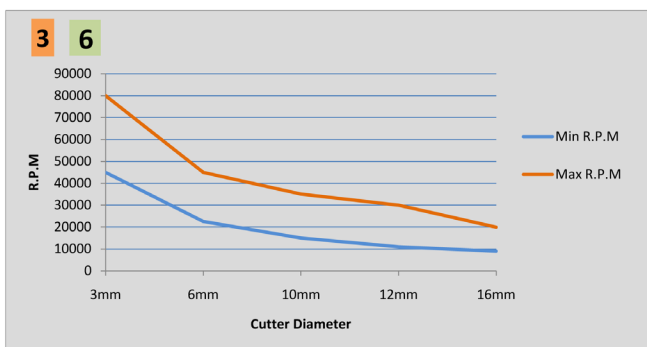
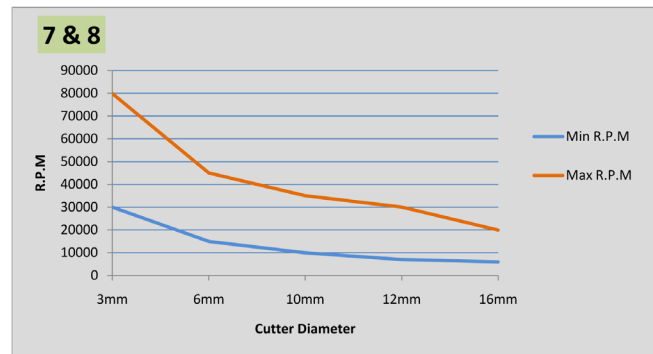
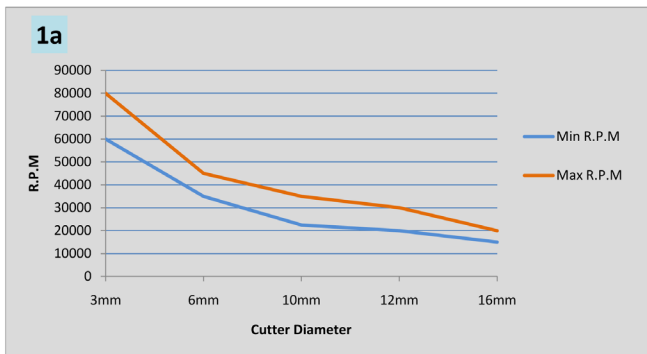

Technical data

Technische Daten / Données techniques / Datos técnicos

Notes

- It may be necessary to adjust the rates shown to achieve optimum performance
- Harder materials require slower speeds
- Smaller burs require faster speeds
- Extra long burs (>150mm long) require slower speeds
- Apply constant movement and light pressure when in use
- Running below the optimum speed will encourage chipping
- Running above optimum speed will cause tooth wear
- Allowing the tool to become too hot may cause the braze to melt and detach the head from the shank
- Using tools and collets that have become worn will encourage chipping
- Do not sink the bur for more than one third of its periphery.

Hinweise

- Um eine optimale Leistung zu erreichen, kann es erforderlich sein, dass die angegebenen Drehzahlwerte geringfügig geregelt werden müssen
- Härtere Materialien erfordern geringere Drehzahlen
- Kleinere Fräser erfordern höhere Drehzahlen
- Extralange Fräser (Länge > 150 mm) erfordern geringere Drehzahlen
- Beim Arbeiten die Bewegung konstant halten und leichten Druck aufbringen
- Arbeiten unter der optimalen Drehzahl begünstigt das Aussplittern
- Arbeiten über der optimalen Drehzahl führt zum verstärkten Zähneverschleiß
- Wenn man das Werkzeug zu heiß werden lässt, kann die Hartötverbindung schmelzen und der Kopf lösen sich vom Schaft
- Durch die Benutzung verschlissener Werkzeuge und Klemmhülsen wird das Aussplittern begünstigt
- Den Fräser nicht mehr als ein Drittel seines Umfangs in das Material senken.

Notes

- Il faudra peut-être modifier les vitesses indiquées pour optimiser les performances de fonctionnement
- Pour les matériaux plus durs, utiliser des vitesses plus lentes
- Pour les bavures plus petites, utiliser des vitesses plus rapides
- Pour les bavures particulièrement longues (>150 mm de long), utiliser des vitesses plus lentes
- Durant l'utilisation, déplacer constamment l'outil en appliquant une légère pression
- Une utilisation en dessous de la vitesse optimale favorisera la formation d'éclats
- Une utilisation au-dessus de la vitesse optimale entraînera une usure des dents
- En cas de surchauffe de l'outil, le brasage risque de fondre provoquant le détachement de la tête
- L'emploi d'outils et de douilles de serrage usés risque de provoquer la formation d'éclats.
- Ne pas enfoncer la fraise-lime de plus d'un tiers de sa périphérie.







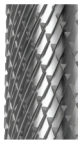

Notas

- Puede que sea necesario ajustar las velocidades indicadas para obtener un óptimo rendimiento
- Los materiales más duros necesitan velocidades más lentas
- Las fresas más pequeñas necesitan velocidades más rápidas
- Las fresas de serie extra largas (>150mm serie larga) necesitan velocidades más lentas
- Aplique un movimiento constante y una ligera presión al utilizarla
- El funcionamiento por debajo de la velocidad óptima provocará astillas
- El funcionamiento por encima de la velocidad óptima provocará el desgaste del diente
- El permitir que la herramienta se caliente demasiado puede hacer que la unión se derrita y se separe el cabezal del eje.
- Al utilizar herramientas y pinzas portapiezas desgastadas se provocarán astillas
- No hunda la fresa más de un tercio de su periferia.

Application Data

Anwendungsgebiete / Données relatives aux applications / Datos de aplicaciones

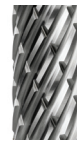
Application by cut style Anwendung nach Schnittauführung / Applications en fonction du style de coupe / Aplicación por estilo de dentado

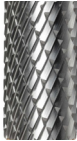
	Standard	Double	Chipbreak	Finecut	d-max™	Aluminium	AS	Steel	Inox	BM
										
Steel Stahl Acier Acero	●	●	●	○	●			○		●
Hardened steel Gehärteter Stahl Acier trempé Acero cementado	○	○		●				●		
Stainless steel Edelstahl Acier inoxydable Acero inoxidable	●	●	●	●	○				●	
Cast iron Gußeisen Fonte Hierro fundido	●	●	○	○	●			○		
Titanium Titan Titane Titanio	●	●		○	○		●			
Nickel Nickel Nickel Níquel	●	●		○	○		●			●
Copper / copper alloys Kupfer / Kupferlegierungen Cuivre / alliages de cuivre Cobre / aleaciones de cobre	●	●	●	○	●					●
Aluminium Aluminium Aluminium Aluminio						●				
Plastics Kunststoff Plastiques Plásticos						●				
Cermet Cermet Cerment Cermet	○			●						

● = highly recommended
sehr empfohlen
hautement recommandé
muy recomendado

○ = recommended
empfohlen
recommandé
recomendado

All burs are 100% braze tested for strength and safety.

Die Hartötverbindungen aller Fräser werden zu 100% auf Festigkeit und Sicherheit geprüft. Toutes nos fraises-limes sont testées pour garantir leur solidité et leur sécurité d'utilisation. Inspeccionamos la totalidad de las fresas fabricadas, y de esta forma, aseguramos su calidad, potencia y seguridad.



skip flute

Our end cut burs are produced with 'skip flute', giving improved cutting action on the Bur end.

Unsere Stirnfräser werden mit "skip flute" hergestellt, womit eine verbesserte Schneidwirkung an der Fräserstirnseite erzielt wird.

Nos fraises avec coupe en bout sont fabriquées avec la technologie 'skip flute' qui leur procure une coupe améliorée en tête de fraise.

Nuestras fresas con dentado frontal se producen con 'skip flute', lo que permite una mejor acción de corte en el extremo de la fresa.

Tungsten carbide burs

Hartmetallfrässtifte

Fraises limes en carbure de tungstène

Fresas rotativas de metal duro

Shape (Forme, Forma)

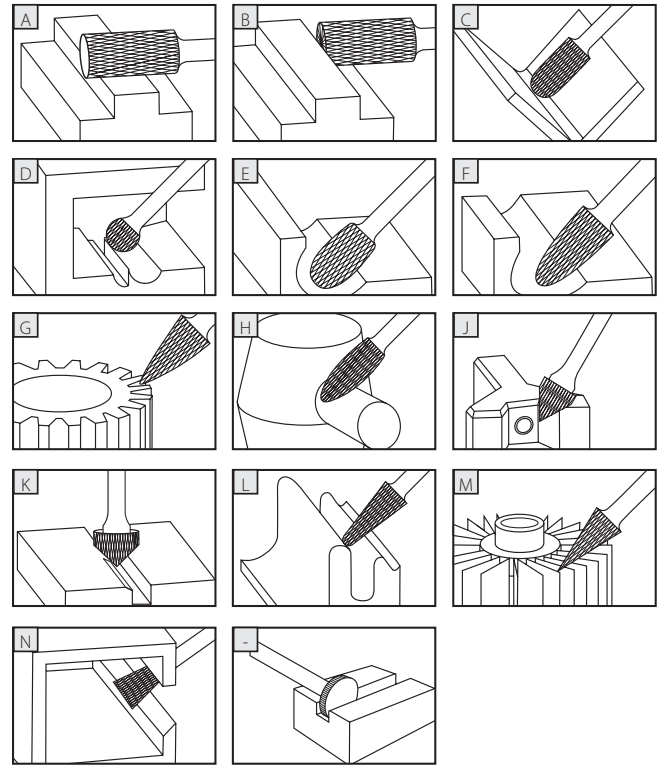

Standard Cut (Standard, Estándar)



General purpose deburring for use on most ferrous metals
Fraise-lime polyvalente à utiliser sur la plupart des matériaux ferreux
Desbarbado de uso general para la mayoría de los materiales férricos

Double Cut (Double coupe, Diamant, Diamante)

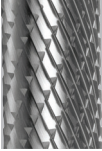

Universal cutting style for use on most ferrous metals
Style de coupe universelle à utiliser sur la plupart des matériaux ferreux
Dentado universal de corte para la mayoría de los materiales férricos

D-Max / Coarse Cut (D-Max, D-Max, D-Max)

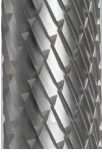

Extra strong tooth formation for fast metal removal
Dents extra résistantes pour une élimination rapide du métal
Formación extra-fuerte de los dientes para una eliminación rápida del metal

Chip Break / Cross Cut (Briser copeaux, Spanbruch, Cortavirutas)



Short chip formation for use on high tensile steels
Formation de copeaux courts, à utiliser sur les aciers à haute résistance à la traction
Formación de viruta corta para uso con aceros de alta resistencia

Fine Cut (Double coupe fine, Feindiamant, Adiamantado fino)



Provides excellent surface finish, ideal for hardened steels & fine finishing
Procure une excellente finition des surfaces, idéal pour les applications à finition fine
Proporciona un excelente acabado superficial, ideal para aplicaciones con acabado fino

Aluminium Cut (Coupe Aluminium, Aluminium, Aluminio)



Avoids clogging teeth and ensures smooth operation, ideal for aluminium, brass and soft materials
Evite l'encrassement des dents et garantit une souplesse de fonctionnement, idéal pour l'aluminium, le laiton et les matériaux mous
Produce un arranque fácil de viruta, ideal para aluminio, latón y materiales blandos

AS Cut (Alloy Specific, Spéciale alliages)



Alloy specific cut suitable for Ni-Alloys & Ti-Alloys
Geeignet für Ni- und Ti- Legierungen
Pour les alliages de nickel et de titane

Inox Cut (Inox schnitt, inox coupé, inoxidable corte)



High performance grinding on stainless steel applications
Hohe Leistung bei Edelstahlschleifanwendungen
Haute performance d'é bardage sur les applications en acier inoxydable
Gran rendimiento para el desbaste en aplicaciones sobre acero inoxidable

Steel Cut (Stahl schneiden, acier coupé, corte de acero)

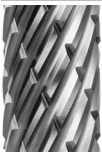





Aggressive cutting form for increased stock removal
Aggressive Schnittform für erhöhte Zerspanungsleistung
Géométrie spécialement conçue pour optimiser le rendement de l'usinage des composants en acier
Corte agresivo para incrementar la eliminación de material

Base Metal (BM, Grundmetallfrässtifte, Métal de base)





Rapid stock removal on soft ferrous materials
Schneller Abtrag auf weichen Eisenwerkstoffen
Enlèvement rapide des matériaux ferreux doux

Range (Gamme, Sortiment, Gama)

	Coated burs (Fraises revêtues, Beschichtete Rotierfräsern, Fresas Rotativas with recubrimiento)
	Standard burs (Fraises standards, Standard, Estándar)
	Extra long burs (Fraises extra longue, Extra lang, Serie extra larga)
	Miniature burs (Fraises miniatures, Hartmetall Kleinfrässtifte, Miniatura)
	Specials (Spécialités, Sonderprodukte, Productos especiales)
	Aluminium Cut (Coupe Aluminium, Aluminium, Aluminio)

Application Data

Anwendungsgebiete / Données relatives aux applications / Datos de aplicaciones

Application by material type Applications - Matières / Anwendungen - Materialien / Aplicaciones - Materiales			
	RAPIDE-D	RAPIDE-D	RAPIDE-A
			
	d-cut	d-max™	alu
Steel Stahl Acier Acero	●	●	
Hardened steel Gehärteter Stahl Acier trempé Acero cementado	○		
Stainless steel Edelstahl Acier inoxydable Acero inoxidable	○	●	
Cast iron Gußeisen Fonte Hierro fundido	○	●	
Titanium Titan Titane Titanio		○	●
Nickel Nickel Nickel Níquel	●	○	
Copper / copper alloys Kupfer / Kupferlegierungen Cuivre / alliages de cuivre Cobre / aleaciones de cobre	●	●	
Aluminium Aluminium Aluminium Aluminio			●
Plastics Kunststoff Plastiques Plásticos			●

 *Additional lead times may apply on coated burs.
Längere Lieferzeiten dürfen mit beschichteten Hartmetallfrä斯塔ifen gefen.

 *Délais de livraison peuvent être plus longs pour les fraises limes revêtues.
Las fresas recubiertas pueden tener un plazo de entrega más largo.

● = highly recommended ○ = recommended
sehr empfohlen empfohlen
hautement recommandé recommandé
muy recomendado recomendado



Coated BURS

RAPIDE® coated carbide burs are proven to dramatically improve the performance of the bur.

Coatings Offer:

- Increased anti-friction properties leading to improved chip removal
- Reduced wear of teeth
- Reduced heat build-up
- Reduced forces due to better lubrication.

All these advantages result in extended service life of the tool.

Coating Type

RAPIDE®-A

- Ideal for use on non-ferrous metals such as aluminium, and soft materials
- Low friction properties reduce clogging of Bur teeth
- Reduced clogging leads to greater material removed
- Available on aluminium Burs.

RAPIDE®-D

- Ideal for use on ferrous metals
- Coating hardness >3,300HV gives excellent wear resistance
- Reduced wear results in longer life of the Bur and greater material removed.



FRAISES LIMES revêtues

Les fraises limes carbure revêtues "**RAPIDE**®" ont prouvé qu'elles sont véritablement plus performantes.

Les revêtements offrent:

- Un coefficient de frottement plus faible d'où une meilleure élimination des copeaux
- Une dureté superficielle accrue pour retarder l'usure des arêtes coupantes.
- Une réduction de la montée en température
- Des efforts réduits grâce à un maintien prolongé dans le temps de la qualité de coupe des dents de la fraise.

Tous ces avantages ont pour résultat une plus longue durée de vie de l'outil.

Type de revêtement

RAPIDE®-A

- Idéal pour une utilisation sur des métaux non-ferreux tels que l'aluminium et les matériaux tendres
- Le très faible coefficient de frottement minimise le phénomène d'arête rapportée sur les dents de la fraise et favorise l'évacuation des copeaux
- Disponible sur fraises aluminium.

RAPIDE®-D

- Idéal pour une utilisation sur métaux ferreux
- La dureté du revêtement >3.300HV donne une excellente résistance à l'usure
- Meilleure évacuation des copeaux et durée de vie accrue.



Beschichtete FRÄSER

RAPIDE® Hartmetallfrässtifte (beschichtete) verbessern nachweislich die Leistung des Fräasers.

Beschichtungen bieten:

- Erhöhte Eigenschaften zur Reibungsverminderung, was zu einer verbesserten Spanabnahme führt
- Weniger Abnutzung der Zähne
- Geringere Wärmeentwicklung
- Weniger Kraftaufwand dank einer besseren Schmierung.

All diese Vorteile bewirken, dass das Werkzeug länger einsetzbar bleibt.

Beschichtungsarten

RAPIDE®-A

- Optimal für den Einsatz auf nichteisenhaltigen Metallen wie Aluminium und weichen Materialien
- Geringere Reibungseigenschaften dadurch, dass die Zähne des Fräasers sich weniger zusetzen
- Weniger Zusetzung hat eine bessere Materialabtragung zur Folge
- Erhältlich auf Aluminiumfräsern.

RAPIDE®-D

- Optimal für die Bearbeitung von eisenhaltigen Metallen
- Beschichtungshärte von >3,300HV für eine ausgezeichnete Abriebfestigkeit
- Geringere Abnutzung führt zu einer längeren Lebensdauer des Fräasers und einer besseren Materialabtragung.



FRESAS DESBARDADORAS recubiertas

Las fresas de metal duro recubiertas **RAPIDE**® han demostrado ser eficaces en la mejora del rendimiento.

Los Recubrimientos Ofrecen:

- Mejores propiedades antifricción, mejorando la extracción de la viruta
- Reducción del desgaste de los dientes
- Reducción de la acumulación de calor
- Reducción del esfuerzo gracias a una mejor lubricación.

Todas estas ventajas dan como resultado una prolongación de la vida útil de la herramienta.

Tipo de Recubrimiento

RAPIDE®-A

- Ideales para su uso en metales no férricos tales como aluminio y materiales blandos
- Las propiedades de baja fricción reducen la obturación de los dientes de desbarrado
- Una obturación reducida permite aumentar la cantidad del material arrancado
- Disponible en las Fresas Desbarradoras para Aluminio.

RAPIDE®-D

- Ideal para su uso sobre metales férricos
- Una dureza del recubrimiento >3.300 HV proporciona una excelente resistencia al desgaste
- Su menor desgaste prolonga la vida útil de la fresa desbarradora, aumentando la cantidad de material arrancada.

Safety Symbols

Sicherheitssymbole / Symboles de sécurité / Símbolos de seguridad



Do not use wet

Nicht im nassen Zustand verwenden
N'utilisez pas ce produit avec de l'eau
No lo use mojado

Wear ear defenders

Gehörschutz tragen
Casque anti-bruit obligatoire
Use protección para los oídos



Wear protective mask

Staubmaske tragen
Veillez porter un masque de protection
Use máscara protectora

Wear safety glasses

Schutzbrille tragen
Veillez porter des lunettes de protection
Use gafas de seguridad



Wear protective gloves

Schutzhandschuhe tragen
Veillez porter des gants de protection
Use guantes protectores

Read Instructions

Anleitung lesen
Veillez lire les instructions
Lea las instrucciones



Garryson®



Tungsten carbide burs

Hartmetallfrässtifte

Fraises limes

Fresas rotativas de
metal duro

Burs

Hartmetallfrässtifte / Fraises limes / Fresas rotativas de metal duro

Cylinder

Zylinderform
Cylindrique
Cilindro

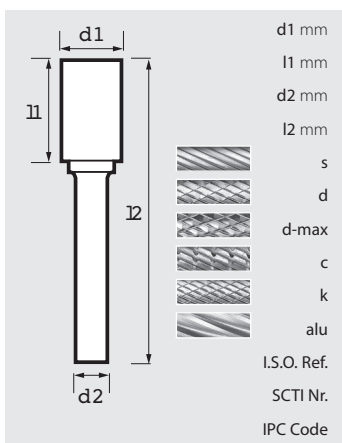
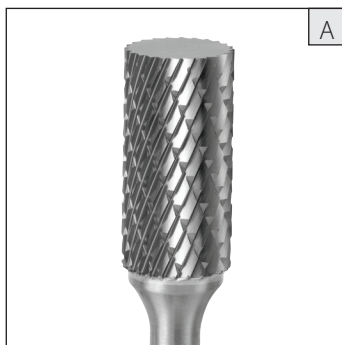
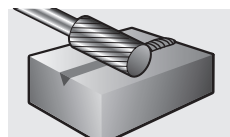

d1 mm	15	24	24	3	3	4	4	4	6	6	6	6	8	
l1 mm	6	13	13	13	13	13	13	16	13	19	19	25	19	
d2 mm	3	24	24	3	3	4	4	6	3	6	6	6	6	
l2 mm	38	38	63	38	63	50	63	50	45	50	75	50	65	
s	GT1050	GT1100	-	GT1200	-	GT1300	-	GT1300-6	GT1240	GT1400	GT1400L	-	GT1500	
d	GT1050D	GT1100D	GT1100DL	GT1200D	GT1200DL	GT1300D	GT1300DL	GT1300D-6	GT1240D	GT1400D	GT1400DL	GT1400D-1	GT1500D	
d-max	-	-	-	-	-	-	-	-	-	-	-	-	-	
c	-	-	-	-	-	-	-	-	-	GT1400C	-	-	-	
k	-	-	-	GT1200K	-	-	-	-	-	GT1400K	-	-	GT1500K	
alu	-	-	-	-	-	-	-	-	-	GT1A240	-	-	-	
I.S.O. Ref.	-	-	-	A031303	A031303	A041304	A041304	A041304	A061303	A061906	A061906	A062506	A081906	
SCTI Nr.	SA-41M	SA-63M	-	SA-43M	-	-	-	SA-13M	SA-51M	SA-1M	SA-1ML3	SA-1ML	SA-2M	
IPC Code	49	49	49	49	49	49	49	25	49	25	25	25	25	

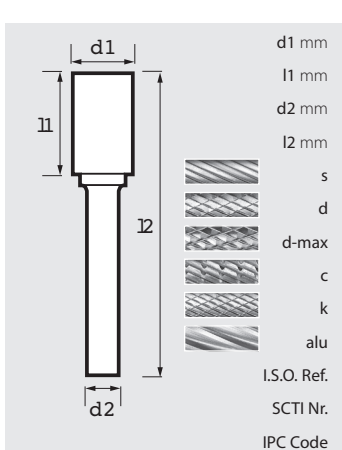
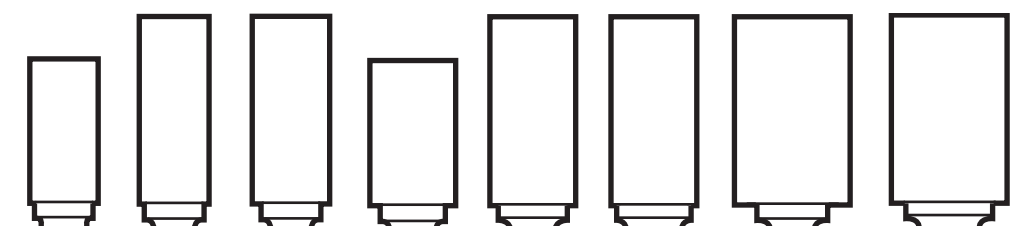

d1 mm	10	10	11	12	12	12	12	12	16	16		
l1 mm	19	25	25	19	25	25	25	25	25	25		
d2 mm	6	6	6	6	6	8	6	8	6	8		
l2 mm	65	70	70	65	70	70	70	70	70	70		
s	GT1600	-	-	GT1700	GT1700-1	GT1700-1-8	GT1800-6	GT1800				
d	GT1600D	GT1600D-1	GT1650D	GT1700D	GT1700D-1	GT1700D-1-8	GT1800D-6	GT1800D				
d-max	GTDX160	-	-	-	GTDX170-1	-	-	-				
c	GT1600C	-	-	GT1700C	-	-	-	-				
k	GT1600K	-	-	GT1700K	GT1700K-1	-	-	-				
alu	GT1A260	-	-	-	GT1A270	-	-	-				
I.S.O. Ref.	A101906	A102506	A112506	A121906	A122506	A122508	A162506	A162508				
SCTI Nr.	SA-3M	SA-3ML	SA-4M	-	SA-5M	SA-5M8	SA-6M	SA-6M8				
IPC Code	25	25	25	25	25	25	25	25				

RAPIDE® Coated burs – Cylinder

RAPIDE® Zylinderform

RAPIDE® Cylindrique

RAPIDE® Cilindro

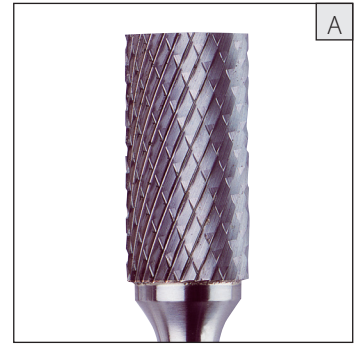
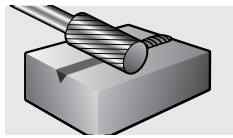

	1.5	2.4	3	3	4	4	6	6	6	8	d1 mm
	6	13	13	13	13	16	13	19	19	19	l1 mm
	3	2.4	3	3	4	6	3	6	6	6	d2 mm
	38	63	38	63	63	50	45	50	75	65	l2 mm
	GCZ1050	-	GCZ1200	-	-	-	GCZ1240	GCZ1400	GCZ1400L	GCZ1500	s- RAPIDE®-D
	-	GCZ1100DL	GCZ1200D	GCZ1200DL	GCZ1300DL	GCZ1300D-6	GCZ1240D	GCZ1400D	GCZ1400DL	GCZ1500D	d- RAPIDE®-D
	-	-	-	-	-	-	-	-	-	-	d-max™ RAPIDE®-D
	-	-	-	-	-	-	-	-	-	-	c- RAPIDE®-D
	-	-	-	-	-	-	-	-	-	-	k- RAPIDE®-D
	-	-	-	-	-	-	-	-	-	-	alu- RAPIDE®-A
	-	-	A031303	A031303	A041304	A041304	A061303	A061906	A061906	A081906	I.S.O. Ref.
	SA-41M	-	SA-43M	-	-	SA-13M	SA-51M	SA-1M	SA-1ML3	SA-2M	SCTI Nr.
	22	22	22	22	22	22	22	22	22	22	IPC Code

	10	11	12	12	12	16	16	d1 mm
	19	25	19	25	25	25	25	l1 mm
	6	6	6	6	8	6	8	d2 mm
	65	70	65	70	70	70	70	l2 mm
	GCZ1600	-	GCZ1700	GCZ1700-1	GCZ1700-1-8	GCZ1800-6	-	s- RAPIDE®-D
	GCZ1600D	GCZ1650D	GCZ1700D	GCZ1700D-1	GCZ1700D-1-8	GCZ1800D-6	-	d- RAPIDE®-D
	GCZDX160	-	-	GCZDX170-1	-	-	-	d-max™ RAPIDE®-D
	-	-	-	-	-	-	-	c- RAPIDE®-D
	-	-	-	-	-	-	-	k- RAPIDE®-D
	GCZTA260	-	-	GCZTA270	-	-	GCZTA280	alu- RAPIDE®-A
	A101906	A112506	A121906	A122506	A122508	A162506	A162508	I.S.O. Ref.
	SA-3M	SA-4M	-	SA-5M	SA-5M8	SA-6M	SA-6M8	SCTI Nr.
	22	22	22	22	22	22	22	IPC Code

*Additional lead times may apply on coated burs.
Längere Lieferzeiten dürfen mit beschichteten Hartmetallfrässtiften gefen.

*Délais de livraison peuvent être plus longs pour les fraises limes revêtues.
Las fresas recubiertas pueden tener un plazo de entrega más largo.

Burs

Hartmetallfrässtifte / Fraises limes / Fresas rotativas de metal duro

Cylinder with end cut

Zylinderform – Mit Stirverzahnung

Cylindre – coupe en bout

Cilindro – con dentado frontal

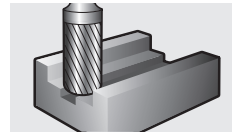
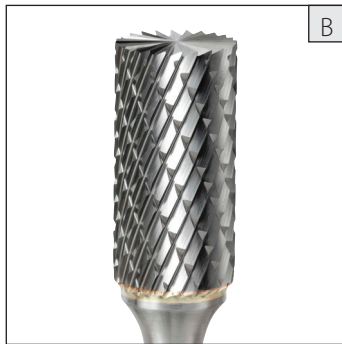

	1	2	3	4	5	6	7	8	9	10	11	12	13
d1 mm	1.5	2.4	2.4	3	3	4	4	4	6	6	6	6	8
l1 mm	6	13	13	13	13	13	13	16	13	19	19	25	19
d2 mm	3	2.4	2.4	3	3	4	4	6	3	6	6	6	6
l2 mm	38	38	63	38	63	50	63	50	45	50	75	50	65
s	GT1052	GT1102	-	GT1202	-	GT1302	-	GT1302-6	GT1242	GT1402	GT1402L	-	GT1502
d	GT1052D	GT1102D	GT1102DL	GT1202D	GT1202DL	GT1302D	GT1302DL	GT1302D-6	GT1242D	GT1402D	GT1402DL	GT1402D-1	GT1502D
d-max	-	-	-	-	-	-	-	-	-	-	-	-	-
c	-	-	-	-	-	-	-	-	-	-	-	-	-
k	-	-	-	GT1202K	-	-	-	-	-	GT1402K	-	-	GT1502K
alu	-	-	-	-	-	-	-	-	-	GTTA140	-	-	-
I.S.O. Ref.	-	-	-	B031303	B031303	B041304	B041304	B041606	B061303	B061906	B061906	B062506	B081906
SCTI Nr.	SB-41M	SB-63M	-	SB-43M	-	-	-	SB-13M	SB-51M	SB-1M	SB-1ML3	SB-1ML	SB-2M
IPC Code	49	49	49	49	49	49	49	25	49	25	25	25	25

	14	15	16	17	18	19	20	21	
d1 mm	10	10	11	12	12	12	12	16	16
l1 mm	19	25	25	19	25	25	25	25	25
d2 mm	6	6	6	6	6	8	6	6	8
l2 mm	65	70	70	65	70	70	70	70	70
s	GT1602	-	-	GT1702	GT1702-1	GT1702-1-8	GT1802-6	GT1802	
d	GT1602D	GT1602D-1	GT1652D	GT1702D	GT1702D-1	GT1702D-1-8	GT1802D-6	GT1802D	
d-max	GTDX162	-	-	-	GTDX172-1	-	-	-	
c	-	-	-	-	-	-	-	-	
k	GT1602K	-	-	GT1702K	GT1702K-1	-	-	-	
alu	GTTA160	-	-	-	GTTA170	-	-	GTTA180	
I.S.O. Ref.	B101906	B102506	B112506	B121906	B122506	B122508	B162506	B162508	
SCTI Nr.	SB-3M	SB-3ML	SB-4M	-	SB-5M	SB-5M8	SB-6M	SB-6M8	
IPC Code	25	25	25	25	25	25	25	25	

RAPIDE® Coated burs – Cylinder with end cut

RAPIDE® Zylinderform – Mit Stirnverzahnung

RAPIDE® Cylindrique – coupe en bout

RAPIDE® Cilindro – con dentado frontal

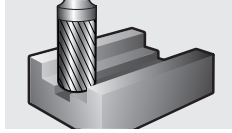

2.4	2.4	3	3	4	4	4	6	6	6	8
13	13	13	13	13	13	16	19	19	25	19
2.4	2.4	3	3	4	4	6	6	6	6	6
38	63	38	63	50	63	50	50	75	50	65
-	-	GCZ1202	-	-	-	GCZ1302-6	GCZ1402	-	-	GCZ1502
GCZ1102D	GCZ1102DL	GCZ1202D	GCZ1202DL	GCZ1302D	GCZ1302DL	-	GCZ1402D	GCZ1402DL	GCZ1402D-1	GCZ1502D
-	-	-	-	-	-	-	-	-	-	-
-	-	-	-	-	-	-	-	-	-	-
-	-	GCZ1202K	-	-	-	-	-	-	-	-
-	-	-	-	-	-	-	-	-	-	-
-	-	-	-	-	-	-	-	-	-	-
-	-	B031303	B031303	B041304	B041304	B041606	B061906	B061906	B062506	B081906
SB-63M	-	SB-43M	-	-	-	SB-13M	SB-1M	SB-1ML3	SB-1ML	SB-2M
22	22	22	22	22	22	22	22	22	22	22

d1 mm
l1 mm
d2 mm
l2 mm
s- RAPIDE®-D
d- RAPIDE®-D
d-max™ RAPIDE®-D
c- RAPIDE®-D
k- RAPIDE®-D
alu- RAPIDE®-A
I.S.O. Ref.
SCTI Nr.
IPC Code

10	12	12	12	16	16
19	19	25	25	25	25
6	6	6	8	6	8
65	65	70	70	70	70
GCZ1602	GCZ1702	GCZ1702-1	GCZ1702-1-8	-	GCZ1802
GCZ1602D	GCZ1702D	GCZ1702D-1	-	GCZ1802D-6	-
GCZDX162	-	GCZDX172-1	-	-	-
-	-	-	-	-	-
GCZ1602K	-	-	-	-	-
GCZTA160	-	GCZTA170	-	-	GCZTA180
B101906	B121906	B122506	B122508	B162506	B162508
SB-3M	-	SB-5M	SB-5M8	SB-6M	SB-6M8
22	22	22	22	22	22

d1 mm
l1 mm
d2 mm
l2 mm
s- RAPIDE®-D
d- RAPIDE®-D
d-max™ RAPIDE®-D
c- RAPIDE®-D
k- RAPIDE®-D
alu- RAPIDE®-A
I.S.O. Ref.
SCTI Nr.
IPC Code

*Additional lead times may apply on coated burs.
Längere Lieferzeiten dürfen mit beschichteten Hartmetallfrässtiften gefen.

*Délais de livraison peuvent être plus longs pour les fraises limes revêtues.
Las fresas recubiertas pueden tener un plazo de entrega más largo.

Burs

Hartmetallfrässtifte / Fraises limes / Fresas rotativas de metal duro

Ball nosed cylinder

Walzenrundform

Cylindrique bout rond

Cilindro esférico

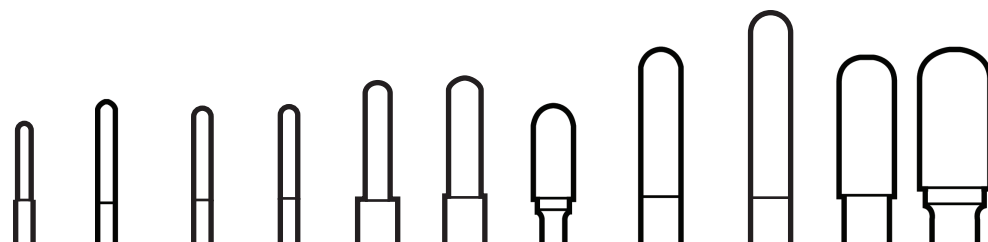
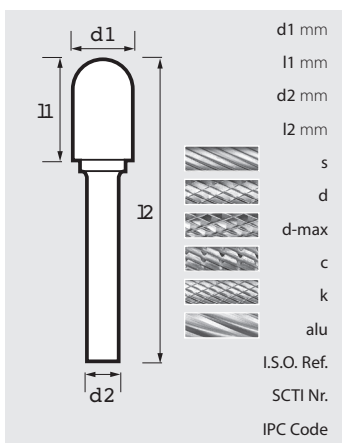
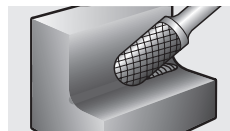

d1 mm	2.5	3	3	3	4	5	6	6	6	8	10
l1 mm	11	13	13	13	16	16	13	19	25	19	19
d2 mm	3	3	3	3	6	6	3	6	6	6	6
l2 mm	38	38	50	75	50	50	45	50	50	65	65
s	GT3100	GT3200	-	-	GT3300-6	-	GT3240	GT3400	-	GT3500	GT3600
d	GT3100D	GT3200D	GT3200DL	GT3200DXL	GT3300D-6	GT3350D-6	GT3240D	GT3400D	GT3400D-1	GT3500D	GT3600D
d-max	-	-	-	-	-	-	-	-	-	GTDX350	GTDX360
c	-	GT3200C	-	-	-	-	-	GT3400C	-	-	GT3600C
k	-	GT3200K	-	-	GT3300K-6	-	-	GT3400K	-	GT3500K	GT3600K
alu	-	-	-	-	-	-	-	GTTA340	-	-	GTTA360
I.S.O. Ref.	-	C031303	C031303	C031303	C041606	C051606	C061303	C061906	C062506	C081906	C101906
SCTI Nr.	SC-41M	SC-42M	SC-42ML2	SC-42ML3	SC-13M	SC-14M	SC-51M	SC-1M	SC-1ML	SC-2M	SC-3M
IPC Code	49	49	49	49	25	25	49	25	25	25	25

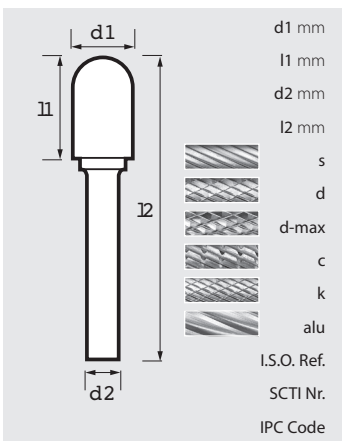
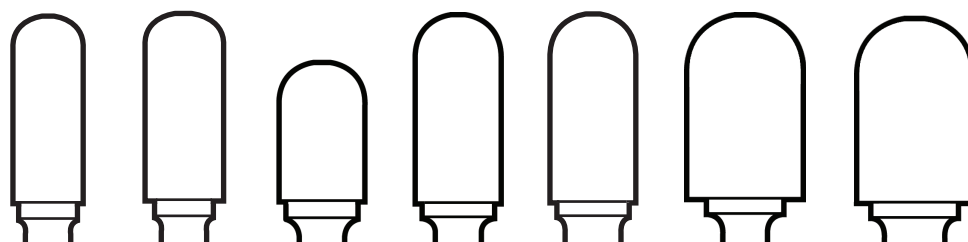

d1 mm	10	11	12	12	12	16	16
l1 mm	25	25	19	25	25	25	25
d2 mm	6	6	6	6	8	6	8
l2 mm	70	70	65	70	70	70	70
s	-	-	GT3700	GT3700-1	GT3700-1-8	GT3800-6	GT3800
d	GT3600D-1	GT3650D	GT3700D	GT3700D-1	GT3700D-1-8	GT3800D-6	GT3800D
d-max	-	-	GTDX370	GTDX370-1	GTDX370-1-8	GTDX380-6	GTDX380
c	-	-	GT3700C	GT3700C-1	-	-	-
k	-	-	GT3700K	GT3700K-1	-	-	-
alu	-	-	-	GTTA370	-	-	GTTA380
I.S.O. Ref.	C102506	C112506	C121906	C122506	C122508	C162506	C162508
SCTI Nr.	SC-3ML	SC-4M	-	SC-5M	SC-5M8	SC-6M	SC-6M8
IPC Code	25	25	25	25	25	25	25

RAPIDE® Coated burs – Ball nosed cylinder

RAPIDE® Walzenrundform

RAPIDE® Cylindrique bout rond

RAPIDE® Cilindro esférico



3	3	4	6	6	6	8	10
13	13	16	13	19	25	19	19
3	3	6	3	6	6	6	6
38	75	50	45	50	50	65	65
-	-	GCZ3300-6	-	GCZ3400	-	GCZ3500	GCZ3600
GCZ3200D	GCZ3200DXL	GCZ3300D-6	GCZ3240D	GCZ3400D	GCZ3400D-1	GCZ3500D	GCZ3600D
-	-	-	-	-	-	GCZDX350	GCZDX360
-	-	-	-	-	-	-	-
-	-	-	-	-	-	-	-
-	-	-	-	-	-	-	GCZTA360
C031303	C031303	C041606	C061303	C061906	C062506	C081906	C101906
SC-42M	SC-42ML3	SC-13M	SC-51M	SC-1M	SC-1ML	SC-2M	SC-3M
22	22	22	22	22	22	22	22

d1 mm	
l1 mm	
d2 mm	
l2 mm	
s- RAPIDE®-D	
d- RAPIDE®-D	
d-max™ RAPIDE®-D	
c- RAPIDE®-D	
k- RAPIDE®-D	
alu- RAPIDE®-A	
I.S.O. Ref.	
SCTI Nr.	
IPC Code	

10	11	12	12	12	16	16
25	25	19	25	25	25	25
6	6	6	6	8	6	8
70	70	65	70	70	70	70
-	-	GCZ3700	GCZ3700-1	GCZ3700-1-8	-	-
GCZ3600D-1	GCZ3650D	GCZ3700D	GCZ3700D-1	GCZ3700D-1-8	-	GCZ3800D
-	-	-	GCZDX370-1	GCZDX370-1-8	GCZDX380-6	-
-	-	-	-	-	-	-
-	-	-	-	-	-	-
-	-	-	GCZTA370	-	-	-
C102506	C112506	C121906	C122506	C122508	C162506	C162508
SC-3ML	SC-4M	-	SC-5M	SC-5M8	SC-6M	SC-6M8
22	22	22	22	22	22	22

d1 mm	
l1 mm	
d2 mm	
l2 mm	
s- RAPIDE®-D	
d- RAPIDE®-D	
d-max™ RAPIDE®-D	
c- RAPIDE®-D	
k- RAPIDE®-D	
alu- RAPIDE®-A	
I.S.O. Ref.	
SCTI Nr.	
IPC Code	

*Additional lead times may apply on coated burs.
Längere Lieferzeiten dürfen mit beschichteten Hartmetallfrässtiften gefen.

*Délais de livraison peuvent être plus longs pour les fraises limes revêtues.
Las fresas recubiertas pueden tener un plazo de entrega más largo.

Burs

Hartmetallfrässtifte / Fraises limes / Fresas rotativas de metal duro

Ball

Kugelform

Sphérique

Esférica

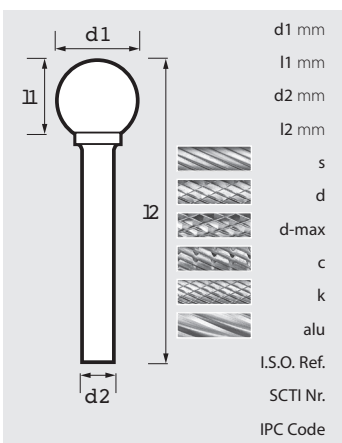
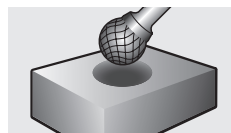

d1 mm	2.5	3	3	4	5	5	6	6	8	10
l1 mm	2.3	2.7	2.5	3.6	4.7	4.7	5.4	5.4	7.2	9
d2 mm	3	3	6	3	3	6	3	6	6	6
l2 mm	38	38	50	45	38	50	38	50	52	53
s	GT7100	GT7200	GT7200-6	GT7300	GT7350	GT7350-6	GT7240	GT7400	GT7500	GT7600
d	GT7100D	GT7200D	GT7200D-6	GT7300D	GT7350D	GT7350D-6	GT7240D	GT7400D	GT7500D	GT7600D
d-max	-	-	-	-	-	-	-	-	-	GTDX760
c	-	GT7200C	-	-	-	-	GT7240C	-	GT7500C	GT7600C
k	-	GT7200K	-	-	-	-	GT7240K	GT7400K	GT7500K	GT7600K
alu	-	-	-	-	-	-	-	GTTA740	-	GTTA760
I.S.O. Ref.	-	D030303	D030306	D040403	D050503	D050506	D060603	D060606	D080806	D101006
SCTI Nr.	SD-41M	SD-42M	SD-11M	SD-52M	SD-53M	SD-14M	SD-51M	SD-1M	SD-2M	SD-3M
IPC Code	49	49	25	49	49	25	49	25	25	25

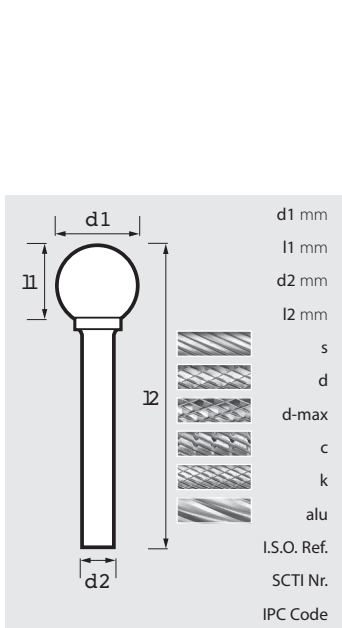

d1 mm	11	12	12	16	16	19	19
l1 mm	9.9	10.8	10.8	14.4	14.4	17.1	17.1
d2 mm	6	6	8	6	8	6	8
l2 mm	54	55	55	60	60	63	63
s	-	GT7700	GT7700-8	GT7800	GT7800-8	GT7900-6	GT7900
d	GT7650D	GT7700D	GT7700D-8	GT7800D	GT7800D-8	GT7900D-6	GT7900D
d-max	-	GTDX770	-	-	-	-	-
c	-	GT7700C	-	-	-	-	-
k	-	GT7700K	-	-	-	-	-
alu	-	GTTA770	GTTA770-8	GTTA780-6	GTTA780	-	-
I.S.O. Ref.	D111106	D121206	D121208	D161606	D161608	D191906	D191908
SCTI Nr.	SD-4M	SD-5M	SD-5M8	SD-6M	SD-6M8	SD-7M	SD-7M8
IPC Code	25	25	25	25	25	25	25

RAPIDE® Coated burs – Ball

RAPIDE® Kugelform

RAPIDE® Sphérique

RAPIDE® Esférica

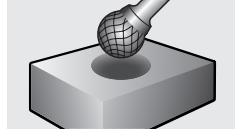

3	3	4	5	6	6	8	10
2.7	2.5	3.6	4.7	5.4	5.4	7.2	9
3	6	3	6	3	6	6	6
38	50	45	50	38	50	52	53
GCZ7200	GCZ7200-6	GCZ7300	GCZ7350-6	GCZ7240	GCZ7400	GCZ7500	GCZ7600
GCZ7200D	GCZ7200D-6	GCZ7300D	-	GCZ7240D	GCZ7400D	GCZ7500D	GCZ7600D
-	-	-	-	-	-	-	GCZDX760
GCZ7200C	-	-	-	GCZ7240C	-	-	-
GCZ7200K	-	-	-	GCZ7240K	-	-	-
-	-	-	-	-	GCZTA740	-	GCZTA760
D030303	-	D040403	-	D060603	D060606	D080806	D101006
SD-42M	SD-11M	SD-52M	SD-14M	SD-51M	SD-1M	SD-2M	SD-3M
22	22	22	22	22	22	22	22

d1 mm	11
l1 mm	11
d2 mm	d2
l2 mm	l2
s- RAPIDE®-D	
d- RAPIDE®-D	
d-max™ RAPIDE®-D	
c- RAPIDE®-D	
k- RAPIDE®-D	
alu- RAPIDE®-A	
I.S.O. Ref.	
SCTI Nr.	
IPC Code	

11	12	12	16	16	19	19
9.9	10.8	10.8	14.4	14.4	17.1	17.1
6	6	8	6	8	6	8
54	55	55	60	60	63	63
-	GCZ7700	GCZ7700-8	GCZ7800	GCZ7800-8	GCZ7900-6	GCZ7900
GCZ7650D	GCZ7700D	GCZ7700D-8	GCZ7800D	GCZ7800D-8	GCZ7900D-6	GCZ7900D
-	GCZDX770	-	-	-	-	-
-	-	-	-	-	-	-
-	-	-	-	-	-	-
-	GCZTA770	-	-	GCZTA780	-	-
D111106	C112506	C121906	C122506	C122508	C162506	C162508
SD-4M	SD-4M	-	SD-5M	SD-5MB	SD-6M	SD-6MB
22	22	22	22	22	22	22

d1 mm	11
l1 mm	11
d2 mm	d2
l2 mm	l2
s- RAPIDE®-D	
d- RAPIDE®-D	
d-max™ RAPIDE®-D	
c- RAPIDE®-D	
k- RAPIDE®-D	
alu- RAPIDE®-A	
I.S.O. Ref.	
SCTI Nr.	
IPC Code	

*Additional lead times may apply on coated burs.
Längere Lieferzeiten dürfen mit beschichteten Hartmetallfrässtiften gefen.

*Délais de livraison peuvent être plus longs pour les fraises limes revêtues.
Las fresas recubiertas pueden tener un plazo de entrega más largo.

Burs

Hartmetallfrässtifte / Fraises limes / Fresas rotativas de metal duro

Oval

Tropfenform

Ovale

Gota

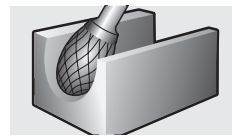

E

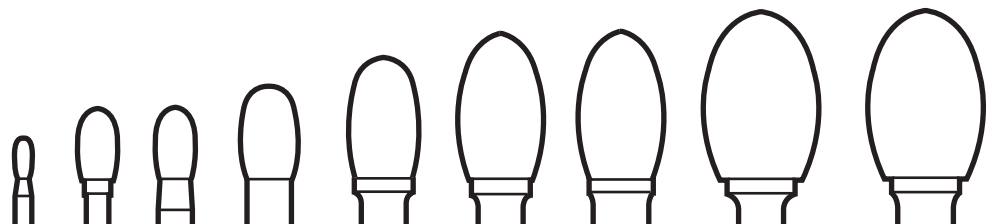

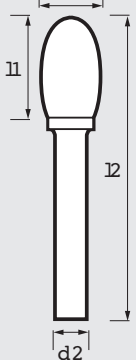
	d1 mm	3	6	6	8	10	12	12	16	16
	l1 mm	6	10	10	13	16	22	22	25	25
	d2 mm	3	3	6	6	6	6	8	6	8
	l2 mm	38	42	50	58	60	67	67	70	70
	s	GT5220	GT5240	-	GT5300	GT5500	GT5700	GT5700-8	GT5800	GT5800-8
	d	GT5220D	GT5240D	GT5260D	GT5300D	GT5500D	GT5700D	GT5700D-8	GT5800D	GT5800D-8
	d-max	-	-	-	-	GTDX550	GTDX570	-	-	-
	c	-	-	-	-	GT5500C	GT5700C	-	-	-
	k	-	-	-	GT5300K	GT5500K	GT5700K	-	-	-
	alu	-	-	-	-	-	-	-	-	-
	I.S.O. Ref.	E030603	E061003	E061006	E081306	E101606	E122206	E122208	E162506	E162508
	SCTI Nr.	SE-41M	SE-51M	SE-1M	SE-2M	SE-3M	SE-5M	SE-5M8	SE-6M	SE-6M8
	IPC Code	49	49	25	25	25	25	25	25	25

RAPIDE® Coated burs – Oval

RAPIDE® Tropfenform

RAPIDE® Ovale

RAPIDE® Gota

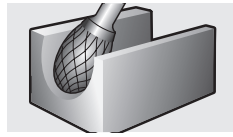

6	8	10	12	12	16	16
10	13	16	22	22	25	25
6	6	6	6	8	6	8
50	58	60	67	67	70	70
-	-	GCZ5500	GCZ5700	GCZ5700-8	GCZ5800	GCZ5800-8
GCZ5260D	GCZ5300D	GCZ5500D	GCZ5700D	GCZ5700D-8	GCZ5800D	-
-	-	GCZDX550	-	-	-	-
-	-	GCZ5500C	-	-	-	-
-	-	-	-	-	-	-
-	-	-	-	-	-	-
E061006	E081306	E101606	E122206	E122208	E162506	E162508
SE-1M	SE-2M	SE-3M	SE-5M	SE-5M8	SE-6M	SE-6M8
22	22	22	22	22	22	22

d1 mm	
11 mm	
d2 mm	
12 mm	
s- RAPIDE®-D	
d- RAPIDE®-D	
d-max™ RAPIDE®-D	
c- RAPIDE®-D	
k- RAPIDE®-D	
alu- RAPIDE®-A	
I.S.O. Ref.	
SCTI Nr.	
IPC Code	

*Additional lead times may apply on coated burs.
Längere Lieferzeiten dürfen mit beschichteten Hartmetallfrässtiften gefen.

*Délais de livraison peuvent être plus longs pour les fraises limes revêtues.
Las fresas recubiertas pueden tener un plazo de entrega más largo.

Burs

Hartmetallfrässtifte / Fraises limes / Fresas rotativas de metal duro

Ball nosed tree

Rundbogenform

Ogive bout rond

Ojival esférica

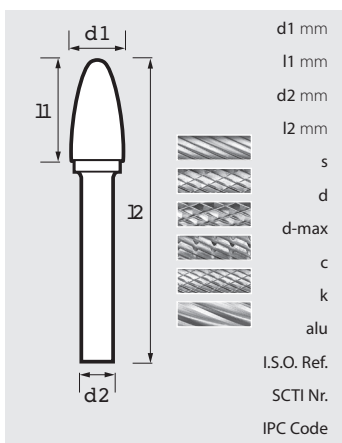
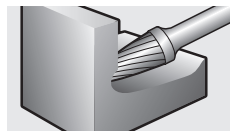

d1 mm	3	3	6	6	10	11	12
l1 mm	6	13	13	16	19	25	19
d2 mm	3	3	3	6	6	6	6
l2 mm	38	38	45	50	65	70	65
s	GT9220	GT9200	GT9240	GT9400	GT9600	-	-
d	GT9220D	GT9200D	GT9240D	GT9400D	GT9600D	GT9650D	GT9730D
d-max	-	-	-	-	GTDX960	-	-
c	-	-	-	GT9400C	GT9600C	-	-
k	-	GT9200K	-	GT9400K	GT9600K	-	-
alu	-	-	-	GTTA940	GTTA960	-	-
I.S.O. Ref.	F030603	F031303	F061303	F061606	F101906	F112506	F121906
SCTI Nr.	SF-41M	SF-42M	SF-51M	SF-1M	SF-3M	SF-4M	-
IPC Code	49	49	49	25	25	25	25

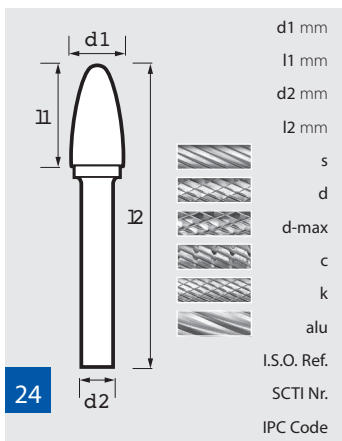
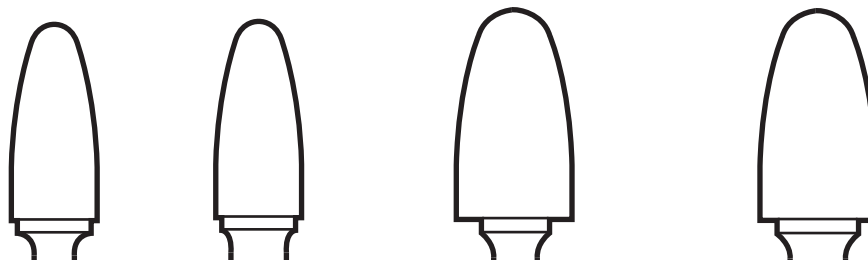

d1 mm	12	12	16	16
l1 mm	25	25	25	25
d2 mm	6	8	6	8
l2 mm	70	70	70	70
s	GT9700	GT9700-8	GT9800-6	GT9800
d	GT9700D	GT9700D-8	GT9800D-6	GT9800D
d-max	GTDX970	GTDX970-8	GTDX980-6	GTDX980
c	GT9700C	-	-	-
k	GT9700K	-	-	-
alu	GTTA970	-	-	GTTA980
I.S.O. Ref.	F122506	F122508	F162506	F162508
SCTI Nr.	SF-5M	SF-5M8	SF-6M	SF-6M8
IPC Code	25	25	25	25

24

RAPIDE® Coated burs – Ball nosed tree

RAPIDE® Rundbogenform

RAPIDE® Ogive bout rond

RAPIDE® Ojival esférica

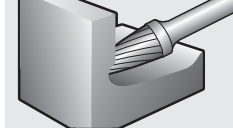

3	3	6	6	10	11
6	13	13	16	19	25
3	3	3	6	6	6
38	38	45	50	65	70
GCZ9220	GCZ9200	GCZ9240	GCZ9400	GCZ9600	-
-	GCZ9200D	GCZ9240D	GCZ9400D	GCZ9600D	GCZ9650D
-	-	-	-	-	-
-	-	-	GCZ9400C	GCZ9600C	-
-	-	-	GCZ9400K	GCZ9600K	-
-	-	-	-	GCZTA960	-
F030603	F031303	F061303	F061606	F101906	F112506
SF-41M	SF-42M	SF-51M	SF-1M	SF-3M	SF-4M
22	22	22	22	22	22

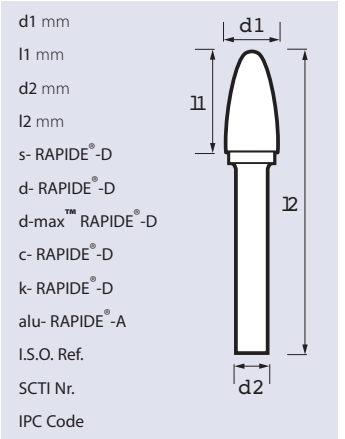

12	12	16	16
25	25	25	25
6	8	6	8
70	70	70	70
GCZ9700	-	-	GCZ9800
GCZ9700D	GCZ9700D-8	GCZ9800D-6	GCZ9800D
GCZDX970	GCZDX970-8	-	-
GCZ9700C	-	-	-
-	-	-	-
GCZTA970	-	-	GCZTA980
F122506	F122508	F162506	F162508
SF-5M	SF-5M8	SF-6M	SF-6M8
22	22	22	22

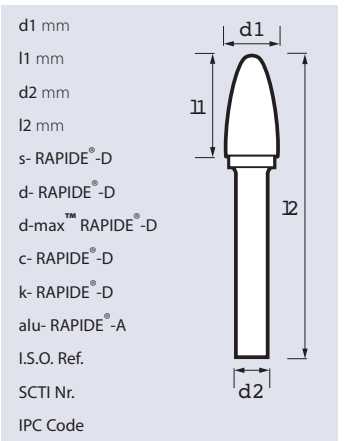

*Additional lead times may apply on coated burs.
 Längere Lieferzeiten dürfen mit beschichteten Hartmetallfrässtiften gefen.

*Délais de livraison peuvent être plus longs pour les fraises limes revêtues.
 Las fresas recubiertas pueden tener un plazo de entrega más largo.

Burs

Hartmetallfrässtifte / Fraises limes / Fresas rotativas de metal duro

Tree

Spitzbogenform

Ogive

Ojival



	3	3	3	6	6	8	10	12
d1 mm	3	3	3	6	6	8	10	12
l1 mm	6	10	13	13	16	19	19	19
d2 mm	3	3	3	3	6	6	6	6
l2 mm	38	38	38	45	50	65	65	65
s	GT6220	GT6230	GT6200	GT6240	GT6400	-	GT6500	GT6700
d	GT6220D	GT6230D	GT6200D	GT6240D	GT6400D	GT6450D	GT6500D	GT6700D
d-max	-	-	-	-	-	-	-	-
c	-	-	-	-	GT6400C	-	GT6500C	-
k	-	-	GT6200K	-	GT6400K	GT6450K	GT6500K	-
alu	-	-	-	-	-	-	-	-
I.S.O. Ref.	G030603	G031003	G031303	G061303	G061606	G081006	G101906	G121906
SCTI Nr.	SG-41M	SG-43M	SG-44M	SG-51M	SG-1M	SG-2M	SG-3M	SG-13M
IPC Code	49	49	49	49	25	25	25	25

	12	12	16	16
d1 mm	12	12	16	16
l1 mm	25	25	25	25
d2 mm	6	8	6	8
l2 mm	70	70	70	70
s	GT6800	GT6800-8	GT6900-6	GT6900
d	GT6800D	GT6800D-8	GT6900D-6	GT6900D
d-max	GTDX680	-	-	-
c	GT6800C	-	-	-
k	GT6800K	-	-	-
alu	-	-	-	-
I.S.O. Ref.	G122506	G122508	G162506	G162508
SCTI Nr.	SG-5M	SG-5M8	SG-6M	SG-6M8
IPC Code	25	25	25	25

RAPIDE® Coated burs – Tree

RAPIDE® Spitzbogenform

RAPIDE® Ogive

RAPIDE® Ojival

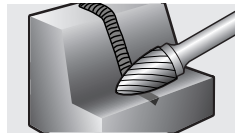

3	3	3	6	6	8	10	12	
6	10	13	13	16	19	19	19	
3	3	3	3	6	6	6	6	
38	38	38	45	50	65	65	65	
-	GCZ6230	GCZ6200	-	GCZ6400	-	GCZ6500	GCZ6700	
GCZ6220D	GCZ6230D	GCZ6200D	GCZ6240D	-	GCZ6450D	GCZ6500D	GCZ6700D	
-	-	-	-	-	-	-	-	
-	-	-	-	-	-	-	-	
-	-	GCZ6200K	-	-	-	-	-	
-	-	-	-	-	-	-	-	
G030603	G031003	G031303	G061303	G061606	G081006	G101906	G121906	
SG-41M	SG-43M	SG-44M	SG-51M	SG-1M	SG-2M	SG-3M	SG-13M	
22	22	22	22	22	22	22	22	

12	12	16	
25	25	25	
6	8	6	
70	70	70	
GCZ6800	-	GCZ6900-6	
GCZ6800D	GCZ6800D-8	GCZ6900D-6	
GCZDX680	-	-	
-	-	-	
-	-	-	
-	-	-	
G122506	G122508	G162506	
SG-5M	SG-5M8	SG-6M	
22	22	22	

*Additional lead times may apply on coated burs.
Längere Lieferzeiten dürfen mit beschichteten Hartmetallfrässtiften gefen.

*Délais de livraison peuvent être plus longs pour les fraises limes revêtues.
Las fresas recubiertas pueden tener un plazo de entrega más largo.

Burs

Hartmetallfrässtifte / Fraises limes / Fresas rotativas de metal duro

Flame

Flammenform

Flamme

Llama

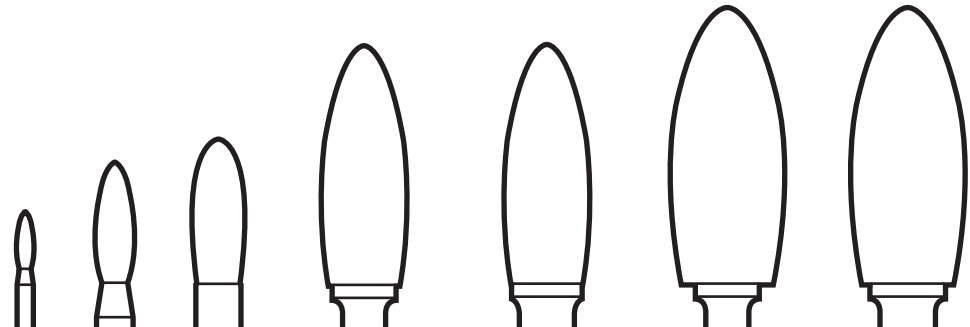
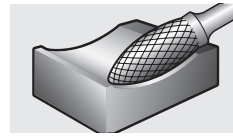

d1 mm	3	6	8	12	12	16	16
l1 mm	8	14	19	32	32	36	36
d2 mm	3	6	6	6	8	6	8
l2 mm	38	50	65	77	77	80	80
s	GT5200	GT5400	GT5550	GT5600	GT5600-8	-	-
d	GT5200D	GT5400D	GT5550D	GT5600D	GT5600D-8	GT5850D-6	GT5850D
d-max	-	-	-	GTD560	-	-	-
c	-	-	GT5550C	GT5600C	-	-	-
k	-	-	GT5550K	GT5600K	-	-	-
alu	-	-	-	-	-	-	-
I.S.O. Ref.	H030803	H061406	H081906	H123206	H123208	H162606	H163608
SCTI Nr.	SH-41M	SH-1M	SH-2M	SH-5M	SH-5M8	SH-6M	SH-6M8
IPC Code	49	25	25	25	25	25	25

RAPIDE® Coated burs – Flame

RAPIDE® Flammenform

RAPIDE® Flamme

RAPIDE® Llama

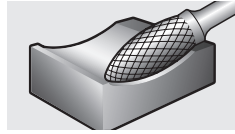

3	8	12	12	16
8	19	32	32	36
3	6	6	8	8
38	65	77	77	80
GCZ5200	GCZ5550	GCZ5600	GCZ5600-8	-
GCZ5200D	GCZ5550D	GCZ5600D	GCZ5600D-8	GCZ5850D
-	-	GCZDX560	-	-
-	GCZ5550C	-	-	-
-	-	-	-	-
-	-	-	-	-
H030803	H081906	H123206	H123208	H163608
SH-41M	SH-2M	SH-5M	SH-5M8	SH-6M8
22	22	22	22	22

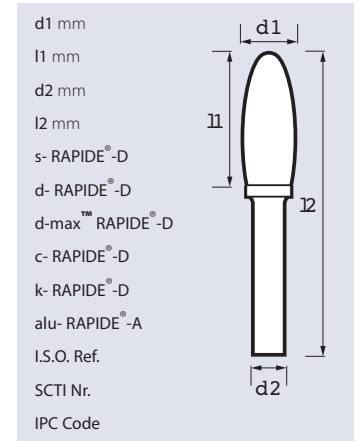

*Additional lead times may apply on coated burs.
Längere Lieferzeiten dürfen mit beschichteten Hartmetallfrässtiften gefen.



*Délais de livraison peuvent être plus longs pour les fraises limes revêtues.
Las fresas recubiertas pueden tener un plazo de entrega más largo.

Burs

Hartmetallfrässtifte / Fraises limes / Fresas rotativas de metal duro

Countersink 60°

Kegelsenkform 60°

Cône 60°

Cono – en grados 60°

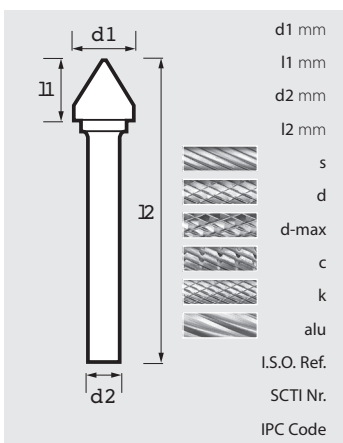
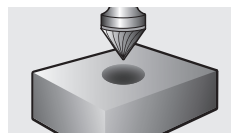

RAPIDE® Coated burs – Countersink 60°

RAPIDE® Kegelsenform 60°

RAPIDE® Cône 60°

RAPIDE® Cono – en grados 60°

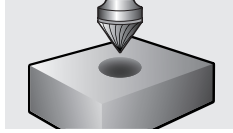

Diagram 1	Diagram 2	Diagram 3	Technical Drawing
6	12	16	d1 mm
4	11	14.5	l1 mm
6	6	6	d2 mm
50	60	60	l2 mm
-	-	-	s- RAPIDE®-D
GCZ2920D	GCZ2900D	GCZ2960D	d- RAPIDE®-D
-	-	-	d-max™ RAPIDE®-D
-	-	-	c- RAPIDE®-D
-	-	-	k- RAPIDE®-D
-	-	-	alu- RAPIDE®-A
J060406	J121106	J161406	I.S.O. Ref.
-	-	-	SCTI Nr.
22	22	22	IPC Code



*Additional lead times may apply on coated burs.
Längere Lieferzeiten dürfen mit beschichteten Hartmetallfrässtiften gefen.



*Délais de livraison peuvent être plus longs pour les fraises limes revêtues.
Las fresas recubiertas pueden tener un plazo de entrega más largo.

Burs

Hartmetallfrässtifte / Fraises limes / Fresas rotativas de metal duro

Countersink 90°

Kegelsenkform 90°

Cône 90°

Cono – en grados 90°

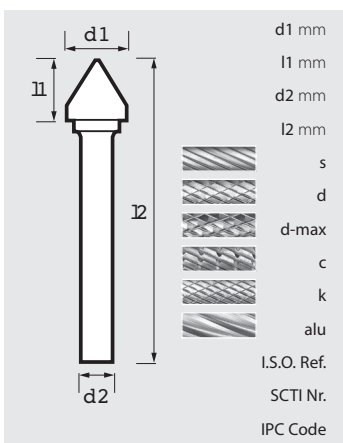
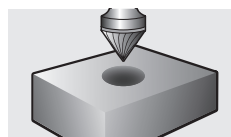

3	6	10	12	16
1.5	3	5	6	8
3	6	6	6	6
38	50	55	54	60
GT2810	GT2820	GT2000	GT2840	GT2800
GT2810D	GT2820D	GT2000D	GT2840D	GT2800D
-	-	-	-	-
-	-	-	-	-
-	-	-	-	-
-	-	-	-	-
-	K060306	K100506	K120606	K160806
SK-42M	SK-1M	SK-3M	SK-5M	SK-6M
49	25	25	25	25



RAPIDE® Coated burs – Countersink 90°

RAPIDE® Kegelsenkform 90°

RAPIDE® Cône 90°

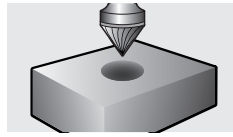
RAPIDE® Cono – en grados 90°



				
	3	10	12	d1 mm
	1.5	5	6	l1 mm
	3	6	6	d2 mm
	38	55	54	l2 mm
	GCZ2810	GCZ2000	GCZ2840	s- RAPIDE®-D
	-	-	-	d- RAPIDE®-D
	-	-	-	d-max™ RAPIDE®-D
	-	-	-	c- RAPIDE®-D
	-	-	-	k- RAPIDE®-D
	-	-	-	alu- RAPIDE®-A
	-	K100506	K120606	I.S.O. Ref.
	SK-42M	SK-3M	SK-5M	SCTI Nr.
	22	22	22	IPC Code

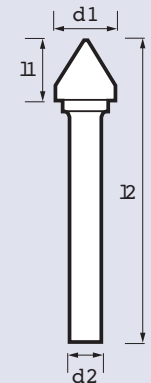

*Additional lead times may apply on coated burs.
Längere Lieferzeiten dürfen mit beschichteten Hartmetallfrässtiften gefen.



*Délais de livraison peuvent être plus longs pour les fraises limes revêtues.
Las fresas recubiertas pueden tener un plazo de entrega más largo.

Burs

Hartmetallfrässtifte / Fraises limes / Fresas rotativas de metal duro

Ball nosed cone

Rundkegelform

Conique bout rond

Cilindro cono esférico

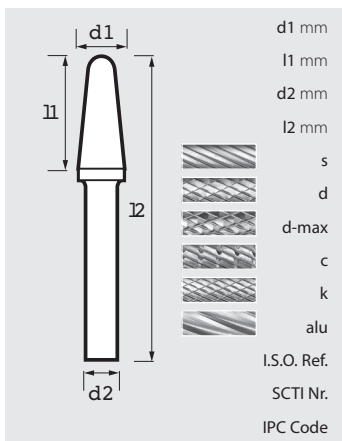
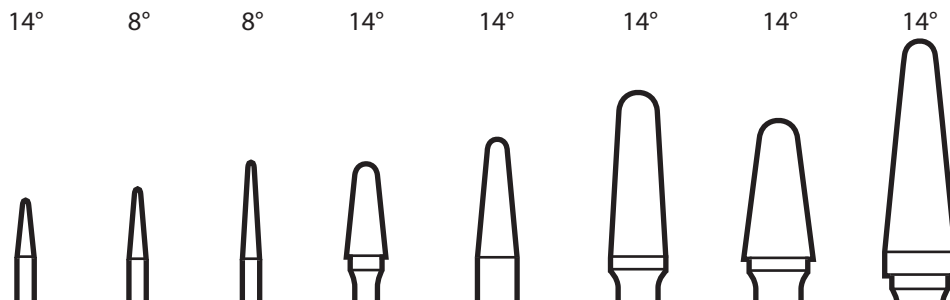
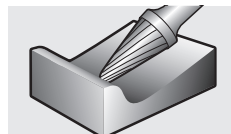

	14°	8°	8°	14°	14°	14°	14°	14°
d1 mm	3	3	3	6	6	8	10	10
l1 mm	8	9.5	13	13	16	22	19	27
d2 mm	3	3	3	3	6	6	6	6
l2 mm	38	38	38	45	50	69	65	75
s	GT4200	GT4210	GT4220	GT4240	GT4400	-	GT4600	GT4600-1
d	GT4200D	GT4210D	GT4220D	GT4240D	GT4400D	GT4500D	GT4600D	GT4600D-1
d-max	-	-	-	-	-	-	-	GTDX460-1
c	-	-	-	-	-	-	GT4600C	-
k	-	-	-	-	GT4400K	-	GT4600K	GT4600K-1
alu	-	-	-	-	GTTA440	-	-	GTTA460
I.S.O. Ref.	L030803	L031003	L031303	L061303	L061606	L101906	L101906	L102706
SCTI Nr.	-	SL-41M	SL-42M	SL-51M	SL-1M	SL-2M	-	SL-3M
IPC Code	49	49	49	49	25	25	25	25

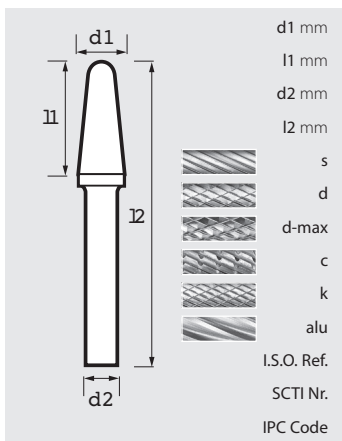
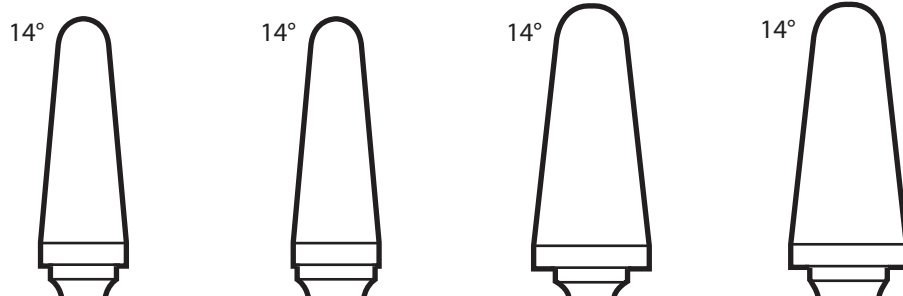

	14°	14°	14°	14°
d1 mm	12	12	16	16
l1 mm	30	30	33	33
d2 mm	6	8	6	8
l2 mm	75	75	78	78
s	GT4700	GT4700-8	GT4800-6	GT4800
d	GT4700D	GT4700D-8	GT4800D-6	GT4800D
d-max	GTDX470	-	-	-
c	GT4700C	-	-	-
k	GT4700K	-	-	-
alu	GTTA470	-	-	GTTA480
I.S.O. Ref.	L123006	L123008	L163306	L163308
SCTI Nr.	SL-4M	SL-4M8	SL-5M	SL-5M8
IPC Code	25	25	25	25

RAPIDE® Coated burs – Ball nosed cone

RAPIDE® Rundkegelform

RAPIDE® Conique bout rond

RAPIDE® Cilindro cono esférico

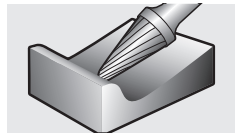

14°	8°	8°	14°	14°	14°	14°	14°
3	3	3	6	6	8	10	10
8	9.5	13	13	16	22	19	27
3	3	3	3	6	6	6	6
38	38	38	45	50	69	65	75
GCZ4200	-	GCZ4220	-	-	-	GCZ4600	GCZ4600-1
GCZ4200D	GCZ4210D	GCZ4220D	GCZ4240D	GCZ4400D	GCZ4500D	-	GCZ4600D-1
-	-	-	-	-	-	-	GCZDX460-1
-	-	-	-	-	-	-	-
-	-	-	-	-	-	-	-
-	-	-	-	-	-	-	GCZTA460
L030803	-	L031303	L061303	L061606	L101906	L101906	L102706
-	SL-41M	SL-42M	SL-51M	SL-1M	SL-2M	-	SL-3M
22	22	22	22	22	22	22	22

d1 mm
l1 mm
d2 mm
l2 mm

s- RAPIDE®-D
d- RAPIDE®-D
d-max™ RAPIDE®-D
c- RAPIDE®-D
k- RAPIDE®-D
alu- RAPIDE®-A

I.S.O. Ref.
SCTI Nr.
IPC Code

14°	14°	14°	14°
12	12	16	16
30	30	33	33
6	8	6	8
75	75	78	78
GCZ4700	-	-	-
GCZ4700D	GCZ4700D-8	GCZ4800D-6	GCZ4800D
GCZDX470	-	-	-
-	-	-	-
GCZ4700K	-	-	-
GCZTA470	-	-	-
L123006	L123008	L163306	L163308
SL-4M	SL-4M8	SL-5M	SL-5M8
22	22	22	22

d1 mm
l1 mm
d2 mm
l2 mm

s- RAPIDE®-D
d- RAPIDE®-D
d-max™ RAPIDE®-D
c- RAPIDE®-D
k- RAPIDE®-D
alu- RAPIDE®-A

I.S.O. Ref.
SCTI Nr.
IPC Code

*Additional lead times may apply on coated burs.
Längere Lieferzeiten dürfen mit beschichteten Hartmetallfrässtiften gefen.

*Délais de livraison peuvent être plus longs pour les fraises limes revêtues.
Las fresas recubiertas pueden tener un plazo de entrega más largo.

Burs

Hartmetallfrässtifte / Fraises limes / Fresas rotativas de metal duro

Cone

Spitzkegelform
Conique
Cono

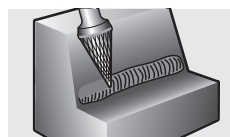

M

12° 7° 22° 22° 14° 11° 28°

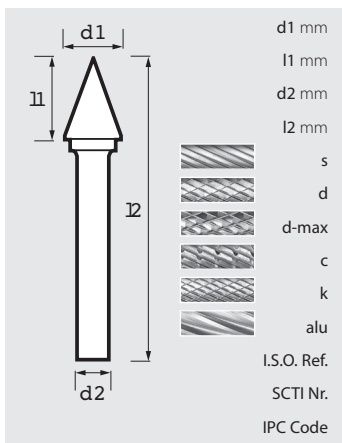
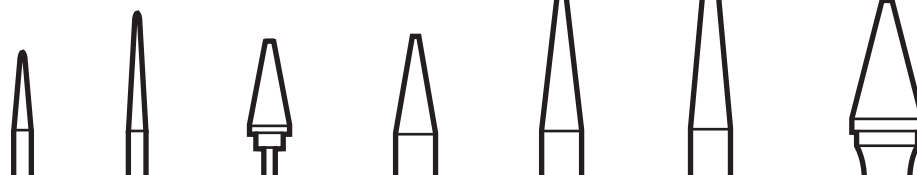

	12°	7°	22°	22°	14°	11°	28°
d1 mm	3	3	6	6	6	6	10
l1 mm	11	16	13	13	19	25	16
d2 mm	3	3	3	6	6	6	6
l2 mm	38	38	45	50	50	50	65
s	GT2200	GT2220	GT2240	-	GT2400	-	GT2600
d	GT2200D	GT2220D	GT2240D	GT2300D	GT2400D	GT2400D-1	GT2600D
d-max	-	-	-	-	-	-	-
c	-	-	-	-	-	-	GT2600C
k	GT2200K	-	-	-	GT2400K	-	GT2600K
alu	-	-	-	-	-	-	-
I.S.O. Ref.	M031103	M031603	M061303	M061306	M061906	M062506	M101606
SCTI Nr.	SM-42M	SM-43M	SM-51M	SM-1M	SM-2M	SM-3M	SM-4M
IPC Code	49	49	49	25	25	25	25

35° 28° 28° 31° 31°

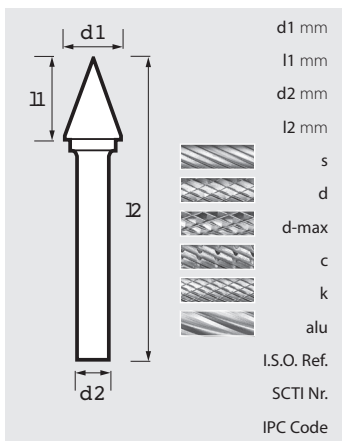
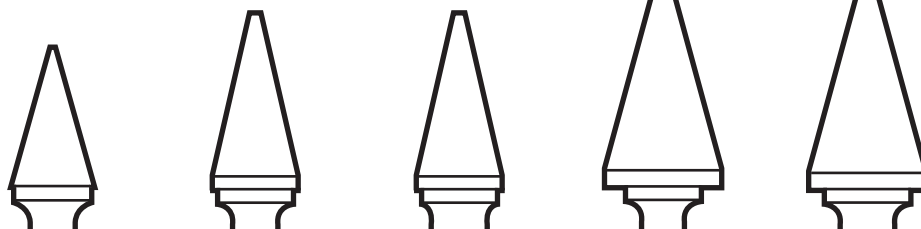

	35°	28°	28°	31°	31°
d1 mm	12	12	12	16	16
l1 mm	19	25	25	25	25
d2 mm	6	6	8	6	8
l2 mm	65	70	70	73	73
s	GT2700	GT2700-1	GT2700-1-8	-	-
d	GT2700D	GT2700D-1	GT2700D-1-8	GT2750D-1-6	GT2750D-1
d-max	-	-	-	-	-
c	-	GT2700C-1	-	-	-
k	-	GT2700K-1	-	-	-
alu	-	-	-	-	-
I.S.O. Ref.	M121906	M122206	M122208	M162206	M162208
SCTI Nr.	SM-13M	SM-5M	SM-5M8	SM-6M	SM-6M8
IPC Code	25	25	25	25	25

RAPIDE® Coated burs – Cone

RAPIDE® Spitzkegelform

RAPIDE® Conique

RAPIDE® Cono

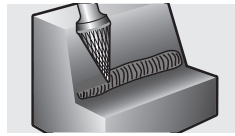

12°	7°	22°	14°	28°
3	3	6	6	10
11	16	13	19	16
3	3	3	6	6
38	38	45	50	65
GCZ2200	GCZ2220	GCZ2240	GCZ2400	GCZ2600
GCZ2200D	GCZ2220D	GCZ2240D	GCZ2400D	GCZ2600D
-	-	-	-	-
-	-	-	-	-
GCZ2200K	-	-	-	-
-	-	-	-	-
M031103	M031603	M061303	M061906	M101606
SM-42M	SM-43M	SM-51M	SM-2M	SM-4M
22	22	22	22	22

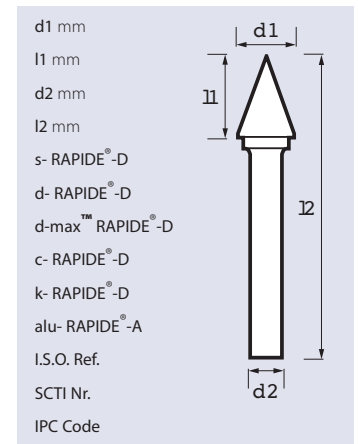

35°	28°	31°	31°
12	12	16	16
19	25	25	25
6	6	6	8
65	70	73	73
GCZ2700	GCZ2700-1	-	-
GCZ2700D	GCZ2700D-1	GCZ2750D-1-6	GCZ2750D-1
-	-	-	-
-	-	-	-
-	-	-	-
-	-	-	-
M121906	M122206	M162206	M162208
SM-13M	SM-5M	SM-6M	SM-6M8
22	22	22	22

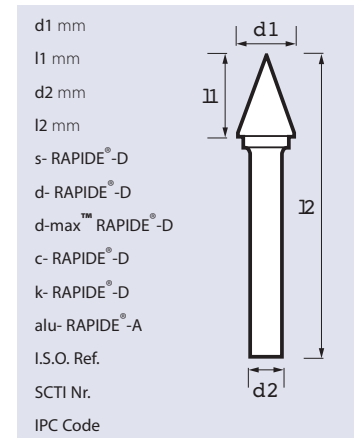

*Additional lead times may apply on coated burs.
 Längere Lieferzeiten dürfen mit beschichteten Hartmetallfrässtiften gefen.

*Délais de livraison peuvent être plus longs pour les fraises limes revêtues.
 Las fresas recubiertas pueden tener un plazo de entrega más largo.

Burs

Hartmetallfrässtifte / Fraises limes / Fresas rotativas de metal duro

Inverted cone

Winkelfrässtifte

Cône inversé

Cono invertido sin dentado frontal

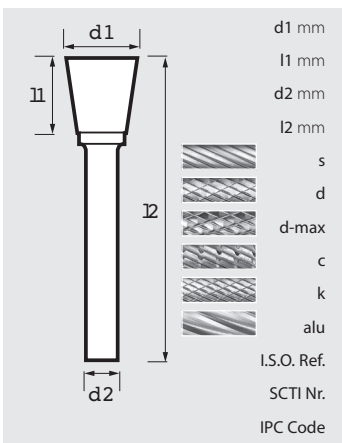
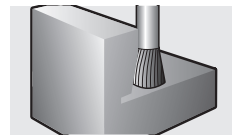

	10°	10°	13°	20°	20°	18°	18°
d1 mm	3	6	9.5	12	12	16	16
l1 mm	7	7	9.5	13	13	19	19
d2 mm	3	6	6	6	8	6	8
l2 mm	38	50	53	58	58	63	63
s	GT8200	GT8400	-	GT8500	GT8500-8	-	-
d	GT8200D	GT8400D	GT8450D	GT8500D	GT8500D-8	GT8800D-6	GT8800D
d-max	-	-	-	-	-	-	-
c	-	-	-	-	-	-	-
k	-	GT8400K	-	GT8500K	-	-	-
alu	-	-	-	-	-	-	-
I.S.O. Ref.	N030703	N060706	-	N121306	N121308	N161906	N161908
SCTI Nr.	SN-42M	SN-1M	SN-2M	SN-4M	SN-4M8	SN-6M	SN-6M8
IPC Code	49	25	25	25	25	25	25

RAPIDE® Coated burs – Inverted cone

RAPIDE® Winkelfrässtifte

RAPIDE® Cône inversé

RAPIDE® Cono invertido sin dentado frontal

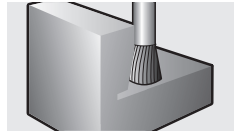

10° 10° 13° 20° 20° 18°

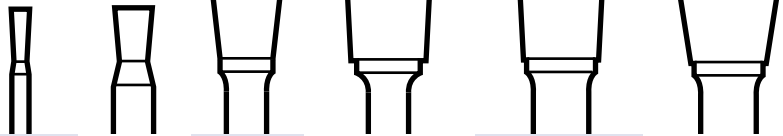

3	6	9.5	12	12	16
7	7	9.5	13	13	19
3	6	6	6	8	8
38	50	53	58	58	63
-	GCZ8400	-	-	GCZ8500-8	-
GCZ8200D	GCZ8400D	GCZ8450D	GCZ8500D	-	GCZ8800D
-	-	-	-	-	-
-	-	-	-	-	-
-	-	-	-	-	-
-	-	-	-	-	-
N030703	N060706	-	N121306	N121308	N161908
SN-42M	SN-1M	SN-2M	SN-4M	SN-4M8	SN-6M8
22	22	22	22	22	22

d1 mm	
l1 mm	
d2 mm	
l2 mm	
s- RAPIDE®-D	
d- RAPIDE®-D	
d-max™ RAPIDE®-D	
c- RAPIDE®-D	
k- RAPIDE®-D	
alu- RAPIDE®-A	
I.S.O. Ref.	
SCTI Nr.	
IPC Code	



*Additional lead times may apply on coated burs.
Längere Lieferzeiten dürfen mit beschichteten Hartmetallfrässtiften gefen.



*Délais de livraison peuvent être plus longs pour les fraises limes revêtues.
Las fresas recubiertas pueden tener un plazo de entrega más largo.

Burs

Hartmetallfrässtifte / Fraises limes / Fresas rotativas de metal duro

Rim

Scheibenform
Fraise disque
Disco

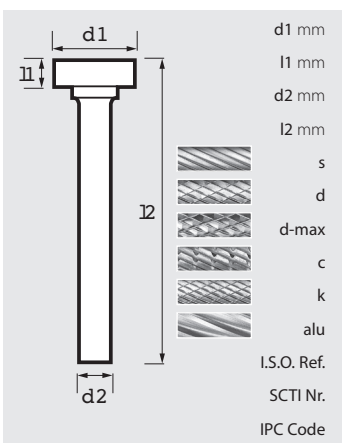
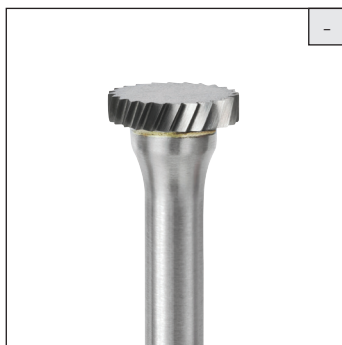
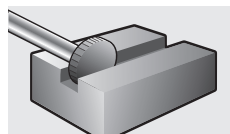

d1 mm	10	12	25	25
l1 mm	1.6	2.6	5.2	6.3
d2 mm	3	6	8	8
l2 mm	34	48	50	51
s	GT8240	GT8700	GT8100	GT9100
d	-	-	-	-
d-max	-	-	-	-
c	-	-	-	-
k	-	-	-	-
alu	-	-	-	-
I.S.O. Ref.	-	-	-	-
SCTI Nr.	-	-	-	-
IPC Code	49	25	25	25

RAPIDE® Coated burs – Rim

RAPIDE® Scheibenform

RAPIDE® Fraise disque

RAPIDE® Disco

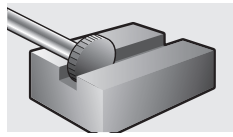

10
1.6
3
34
GCZ8240
-
-
-
-
-
-
-
-
22



12
2.6
6
48
GCZ8700
-
-
-
-
-
-
-
-
22

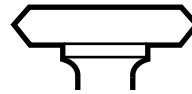

25
5.2
8
50
GCZ8100
-
-
-
-
-
-
-
-
22

d1 mm
l1 mm
d2 mm
l2 mm
s- RAPIDE®-D
d- RAPIDE®-D
d-max™ RAPIDE®-D
c- RAPIDE®-D
k- RAPIDE®-D
alu- RAPIDE®-A
I.S.O. Ref.
SCTI Nr.
IPC Code

*Additional lead times may apply on coated burs.
Längere Lieferzeiten dürfen mit beschichteten Hartmetallfrässtiften gefen.

*Délais de livraison peuvent être plus longs pour les fraises limes revêtues.
Las fresas recubiertas pueden tener un plazo de entrega más largo.

Burs

Hartmetallfrässtifte / Fraises limes / Fresas rotativas de metal duro

Miniature burs

Hartmetall Kleinfrässtifte

Mini fraises carbure

Fresas rotativas de metal duro - miniatura

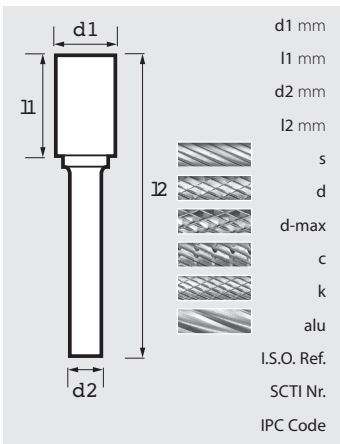

d1 mm	1.5	2.4	2.4	3	3	6	1.5	2.4	2.4	3	3	6
l1 mm	6	13	13	13	13	13	6	13	13	13	13	13
d2 mm	3	2.4	2.4	3	3	3	3	2.4	2.4	3	3	3
l2 mm	38	38	63	38	63	45	38	38	63	38	63	45
s	GT1050	GT1100	-	GT1200	-	GT1240	GT1052	GT1102	-	GT1202	-	GT1242
d	GT1050D	GT1100D	GT1100DL	GT1200D	GT1200DL	GT1240D	GT1052D	GT1102D	GT1102DL	GT1202D	GT1202DL	GT1242D
d-max	-	-	-	-	-	-	-	-	-	-	-	-
c	-	-	-	-	-	-	-	-	-	-	-	-
k	-	-	-	T1200K	-	-	-	-	-	T1202K	-	-
alu	-	-	-	-	-	-	-	-	-	-	-	-
I.S.O. Ref.	-	-	-	A031303	A031303	A061303	-	-	-	B031303	B031303	B061303
SCTI Nr.	SA-41M	SA-63M	-	SA-43M	-	SA-51M	SB-41M	SB-63M	-	SB-43M	-	SB-51M
IPC Code	49	49	49	49	49	49	49	49	49	49	49	49

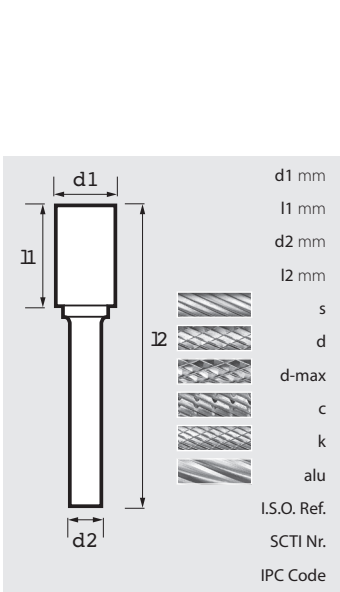

d1 mm	2.5	3	3	3	6	2.5	3	4	5	6
l1 mm	11	13	13	13	13	2.3	2.7	3.6	4.7	5.4
d2 mm	3	3	3	3	3	3	3	3	3	3
l2 mm	38	38	50	75	45	38	38	45	38	38
s	GT3100	GT3200	-	-	GT3240	GT7100	GT7200	GT7300	GT7350	GT7240
d	GT3100D	GT3200D	GT3200DL	GT3200DXL	GT3240D	GT7100D	GT7200D	GT7300D	GT7350D	GT7240D
d-max	-	-	-	-	-	-	-	-	-	-
c	-	GT3200C	-	-	-	-	GT7200C	-	-	GT7240C
k	-	GT3200K	-	-	-	-	GT7200K	-	-	GT7240K
alu	-	-	-	-	-	-	-	-	-	-
I.S.O. Ref.	-	C031303	C031303	C031303	C061303	-	D030303	D040403	D050503	D060603
SCTI Nr.	SC-41M	SC-42M	SC-42ML2	SC-42ML3	SC-51M	SD-41M	SD-42M	SD-52M	SD-53M	SD-51M
IPC Code	49	49	49	49	49	49	49	49	49	49

Miniature burs

Hartmetall Kleinfrässtifte

Mini fraises carbure

Fresas rotativas de metal duro - miniatura



3	6	3	3	6	3	3	3	6	3	3
6	10	6	13	13	6	10	13	13	8	1.5
3	3	3	3	3	3	3	3	3	3	3
38	42	38	38	45	38	38	38	45	38	38
GT5220	GT5240	GT9220	GT9200	GT9240	GT6220	GT6230	GT6200	GT6240	GT5200	GT2810
GT5220D	GT5240D	GT9220D	GT9200D	GT9240D	GT6220D	GT6230D	GT6200D	GT6240D	GT5200D	GT2810D
-	-	-	-	-	-	-	-	-	-	-
-	-	-	-	-	-	-	-	-	-	-
-	-	-	T9200K	-	-	-	T6200K	-	-	-
-	-	-	-	-	-	-	-	-	-	-
E030603	E061003	F030603	F031303	F061303	G030603	G031003	G031303	G061303	H030803	-
SE-41M	SE-51M	SF-41M	SF-42M	SF-51M	SG-41M	SG-43M	SG-44M	SG-51M	SH-41M	SK-42M
49	49	49	49	49	49	49	49	49	49	49

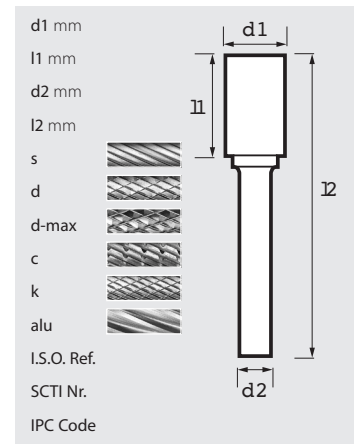

3	3	3	6	3	3	6	3	10	
8	9.5	13	13	11	16	13	7	1.6	
3	3	3	3	3	3	3	3	3	
38	38	38	45	38	38	45	38	34	
GT4200	GT4210	GT4220	GT4240	GT2200	GT2220	GT2240	GT8200	GT8240	
GT4200D	GT4210D	GT4220D	GT4240D	GT2200D	GT2220D	GT2240D	GT8200D	-	
-	-	-	-	-	-	-	-	-	
-	-	-	-	-	-	-	-	-	
-	-	-	-	GT2200K	-	-	-	-	
-	-	-	-	-	-	-	-	-	
L030803	-	L031303	L061303	M031103	M031603	M061303	N030703	-	
-	SL-41M	SL-42M	SL-51M	SM-42M	SM-43M	SM-51M	SN-42M	-	
49	49	49	49	49	49	49	49	49	

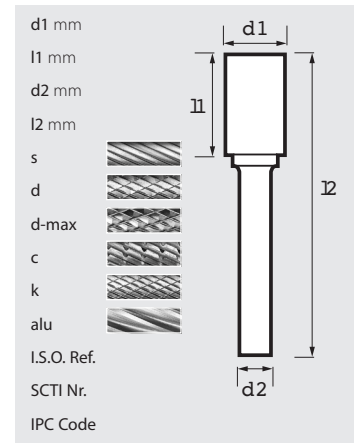

*Additional lead times may apply on coated burs.
Längere Lieferzeiten dürfen mit beschichteten Hartmetallfrässtiften gefen.

*Délais de livraison peuvent être plus longs pour les fraises limes revêtues.
Las fresas recubiertas pueden tener un plazo de entrega más largo.

Burs

Hartmetallfrässtifte / Fraises limes / Fresas rotativas de metal duro

Extra long

Extra lang

Extra longue

Serie extra larga



d1 mm	10	12	10	12	10	12
l1 mm	19	25	19	25	9	10.8
d2 mm	6	6	6	6	6	6
l2 mm	169	175	169	175	159	160.8
s	GT1600XL	GT1700-1XL	GT3600XL	GT3700-1XL	GT7600XL	GT7700XL
d	GT1600DXL	GT1700D-1XL	GT3600DXL	GT3700D-1XL	GT7600DXL	GT7700DXL
d-max	-	-	-	-	-	-
c	-	-	-	-	-	-
k	-	-	-	-	-	-
alu	-	-	-	-	-	-
I.S.O. Ref.	-	-	-	-	-	-
SCTI Nr.	SA-3ML6	SA-5ML6	SC-3ML6	SC-5ML6	SD-3ML6	SD-5ML6
IPC Code	25	25	25	25	25	25

* Max RPM 15,000

d1 mm	10	12	10	12	10	12
l1 mm	19	25	19	25	27	30
d2 mm	6	6	6	6	6	6
l2 mm	169	175	169	175	177	180
s	GT9600XL	GT9700XL	GT6500XL	GT6800XL	GT4600-1XL	GT4700XL
d	GT9600DXL	GT9700DXL	GT6500DXL	GT6800DXL	GT4600D-1XL	GT4700DXL
d-max	-	-	-	-	-	-
c	-	-	-	-	-	-
k	-	-	-	-	-	-
alu	-	-	-	-	-	-
I.S.O. Ref.	-	-	-	-	-	-
SCTI Nr.	SF-3ML6	SF-5ML6	SF-3ML6	SF-5ML6	SL-3ML6	SL-4ML6
IPC Code	25	25	25	25	25	25

* Max RPM 15,000

RAPIDE® Coated burs – Extra long

RAPIDE® Extra lang

RAPIDE® Extra longue

RAPIDE® Serie extra larga



10	10	10	12	12	d1 mm
19	19	19	25	25	l1 mm
6	6	6	6	6	d2 mm
169	169	169	175	175	l2 mm
GCZ1600XL	-	-	GCZ9700XL	-	s- RAPIDE®-D
-	GCZ3600DXL	GCZ9600DXL	GCZ9700DXL	GCZ6800DXL	d- RAPIDE®-D
-	-	-	-	-	d-max™ RAPIDE®-D
-	-	-	-	-	c- RAPIDE®-D
-	-	-	-	-	k- RAPIDE®-D
-	-	-	-	-	alu- RAPIDE®-A
-	-	-	-	-	I.S.O. Ref.
SA-3ML6	SC-3ML6	SF-3ML6	SF-5ML6	SF-5ML6	SCTI Nr.
22	22	22	22	22	IPC Code

* Max RPM 15,000



* Max RPM 15,000



*Additional lead times may apply on coated burs.
Längere Lieferzeiten dürfen mit beschichteten Hartmetallfrässtiften gefen.



*Délais de livraison peuvent être plus longs pour les fraises limes revêtues.
Las fresas recubiertas pueden tener un plazo de entrega más largo.

Garryson®



MATERIAL
SPECIFIC

Garryson®

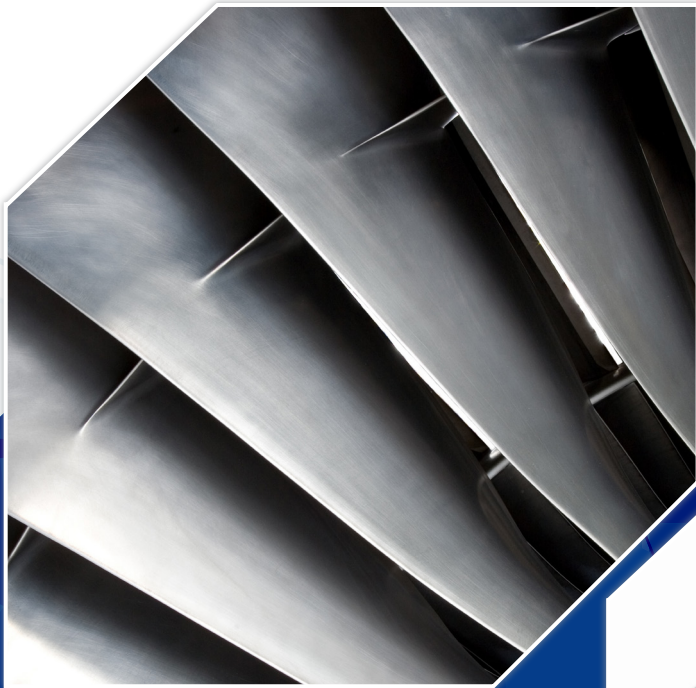

Alloy Specific Range

Suitable for Ni-Alloys & Ti-Alloys



Garryson® ALLOY SPECIFIC RANG

Introducing the new Alloy Specific Bur range from Garryson

Designed specifically to meet the most demanding metal finishing needs of high tech industries.

The geometry has been specifically designed for use on Ni-Alloys & Ti-Alloys.

Our new alloy specific bur geometry offers:

- Advanced cutting geometry, allowing for -
 - Increased stock removal
 - Improved surface finish
 - Increased tool life
 - Controlled cutting action
- High performance grinding - ensuring production savings and reduced downtime
- CNC Machined - high consistent quality
- Combined with the ATA Pencil Grinders, the AS range allows for:
 - A smoother grinding operation
 - Increased productivity

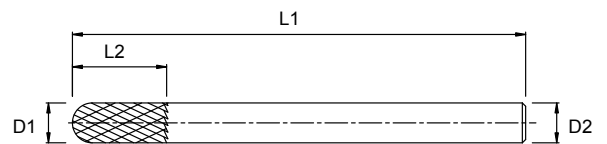

D1	Cutting Diameter
L2	Length of Cut
D2	Shank Diameter
L1	Overall Length



To find out more scan here



Wear Eye Protection!



Wear Hearing Protection!



Observe the recommended rotational speed, especially when using burs with long shanks!



Wear Protective Gloves

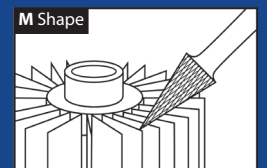
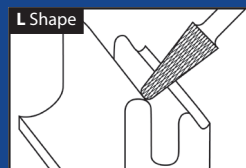
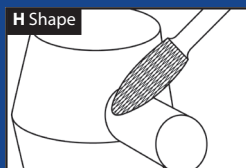
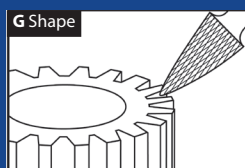
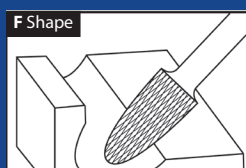
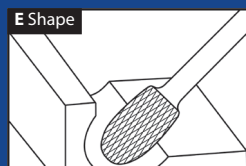
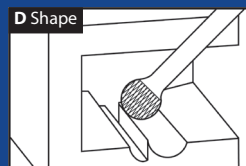
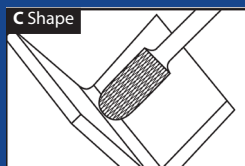
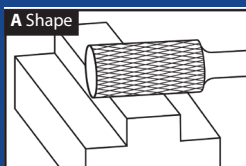

SHAPE A, ZYA, SA



Cylinder without Endcut

Cutting Diameter D1	Length of Cut L2	Shank Diameter D2	Overall Length L1	Part No.
3.0	12.0	3.0	38	GT1200-AS

SHAPE C, WRC, SC



Ball Nosed Cylinder

Cutting Diameter D1	Length of Cut L2	Shank Diameter D2	Overall Length L1	Part No.
3.0	14.0	3.0	38	GT3200-AS

SHAPE D, KUD, SD



Ball Shape

Cutting Diameter D1	Length of Cut L2	Shank Diameter D2	Overall Length L1	Part No.
3.0	2.5	3.0	38	GT7200-AS

SHAPE E, TRE, SE



Oval Shape

Cutting Diameter D1	Length of Cut L2	Shank Diameter D2	Overall Length L1	Part No.
3.0	6.0	3.0	38	GT5220-AS

SHAPE F, RBF, SF



Ball Nosed Tree

Cutting Diameter D1	Length of Cut L2	Shank Diameter D2	Overall Length L1	Part No.
3.0	14.0	3.0	38	GT9200-AS

SHAPE G, SPG, SG



Pointed Tree

Cutting Diameter D1	Length of Cut L2	Shank Diameter D2	Overall Length L1	Part No.
3.0	8.0	3.0	38	GT6220-AS
3.0	14.0	3.0	38	GT6200-AS

SHAPE H, SH



Flame

Cutting Diameter D1	Length of Cut L2	Shank Diameter D2	Overall Length L1	Part No.
3.0	6.0	3.0	38	GT5200-AS

SHAPE L, KEL, SL



Ball Nosed Cone

Cutting Diameter D1	Length of Cut L2	Shank Diameter D2	Overall Length L1	Part No.
3.0	14.0	3.0	38	GT4220-AS

SHAPE M, SKM, SM



Cone

Cutting Diameter D1	Length of Cut L2	Shank Diameter D2	Overall Length L1	Part No.
3.0	15.0	3.0	38	GT2220-AS



Wear Eye Protection!



Wear Hearing Protection!



Observe the recommended rotational speed, especially when using burs with long shanks!



Wear Protective Gloves



AS RANGE SET

Features & Benefits

FEATURES

Compact

Versatile assortment

BENEFITS

Easy to carry

Ideal for demonstrations, samplings or special promotions



Line	Description Type	Contents	Alloy Specific Part No.
Sets	10 pcs Alloy Specific Cut	GT1200-AS; GT3200-AS; GT7200-AS; GT5220-AS; GT9200-AS; GT6220-AS; GT6200-AS; GT5200-AS; GT4220-AS; GT2220-AS	GGBKIT39

AS RANGE SPEED GUIDE

Bur Head Diameter	Maximum Operating Speed	Speed Range	Suggested Air Tools
3mm (1/8")	100,000	45,000 - 100,000	SP Range

Recommended speeds are based on standard overall length of 38mm (1-1/2") maximum overhang of 10mm (3/8")



To find out more scan here

Garryson®



Inox Range

Inox Serie

Gamme Inox

Gama inoxidable



Garryson® INOX RANGE (INOX SERIE, GAMME INOX, GAMA INOXIDABLE)

Garryson Inox Range has a specially designed geometry to suit growing market demands for stainless steel applications. This is a cost effective alternative to standard solutions due to the greater rate of stainless steel stock removal and on Ferritic, Austenitic & Martensitic based materials.

Features & Benefits

- Developed cutting geometry - generating high stock removal on Inox components
- High performance grinding - ensuring production savings and reduced downtime
- Specifically developed Inox cutting geometry - reducing heat build up at the cutting edge and workpiece
- Manufactured from high quality sintered tungsten carbide - guaranteed high performance and durability
- CNC Machined - High consistent quality
- Combination of ATA air tool with Inox cut geometry - gives a guaranteed smoother grinding operation
- Manufactured to strict quality control standards - Incorporates 100% inspection of brazed joints

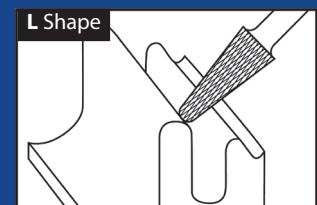
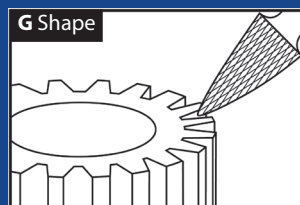
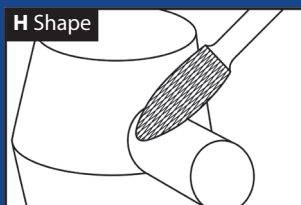
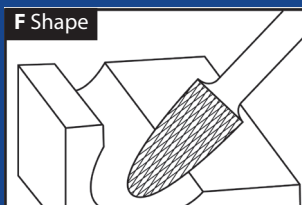
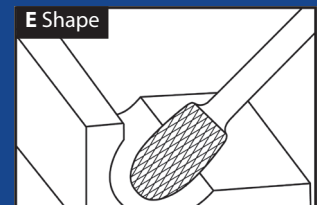
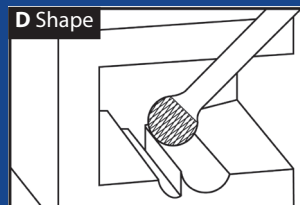
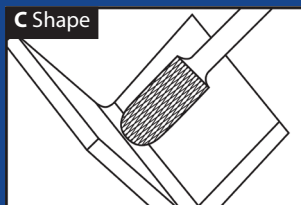
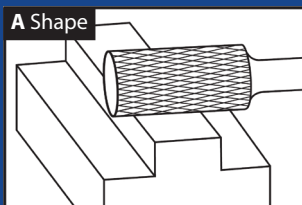

INOX RANGE (INOX SERIE, GAMME INOX, GAMA INOXIDABLE)

A, ZYA, SA

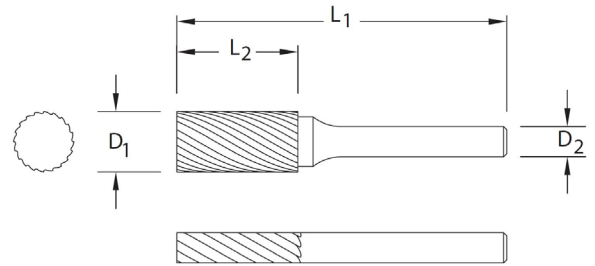

Inox A, ZYA, SA - Cylinder without Endcut (Zylinderform – Mit Stirverzahnung, Cylindre – coupe en bout, Cilindro – con dentado frontal)

Tool	Cutting Diameter D1	Length of Cut L2	Shank Diameter D2	Overall Length L1	Cut - Inox Part No.
SA-43M	3	13	3	38	GT1200-INOX
SA-51M	6	13	3	45	GT1240-INOX
SA-1M	6	19	6	50	GT1400-INOX
SA-2M	8	19	6	65	GT1500-INOX
SA-3M	10	19	6	65	GT1600-INOX
SA-5M	12	25	6	70	GT1700-1-INOX

INOX RANGE (INOX SERIE, GAMME INOX, GAMA INOXIDABLE)

C, WRC, SC

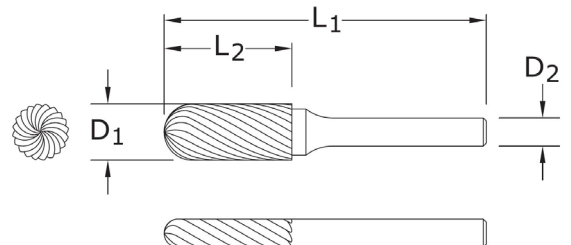

Inox C, WRC, SC - Ball Nosed Cylinder (Walzenrundform, Cylindrique bout rond, Cilindro esférico)

Tool	Cutting Diameter D1	Length of Cut L2	Shank Diameter D2	Overall Length L1	Cut - Inox Part No.
SC-42M	3	13	3	38	GT3200-INOX
SC-51M	6	13	3	45	GT3240-INOX
SC-1M	6	19	6	50	GT3400-INOX
SC-2M	8	19	6	65	GT3500-INOX
SC-3M	10	19	6	65	GT3600-INOX
SC-5M	12	25	6	70	GT3700-1-INOX



Wear Eye Protection!



Wear Hearing Protection!



Observe the recommended rotational speed, especially when using burs with long shanks!



Wear Protective Gloves

INOX RANGE (INOX SERIE, GAMME INOX, GAMA INOXIDABLE)

D, KUD, SD

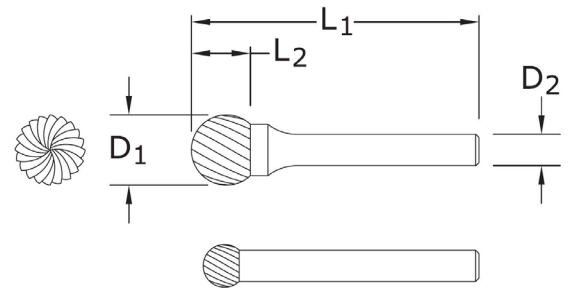

Inox D, KUD, SD - Ball Shape (Kugelform, Sphérique, Esférica)

Tool	Cutting Diameter D1	Length of Cut L2	Shank Diameter D2	Overall Length L1	Cut - Inox Part No.
SD-42M	3	2.7	3	38	GT7200-INOX
SD-51M	6	5.4	3	38	GT7240-INOX
SD-1M	6	5.4	6	50	GT7400-INOX
SD-2M	8	7.2	6	52	GT7500-INOX
SD-3M	10	9	6	53	GT7600-INOX
SD-5M	12	10	6	55	GT7700-INOX

INOX RANGE (INOX SERIE, GAMME INOX, GAMA INOXIDABLE)

E, TRE, SE

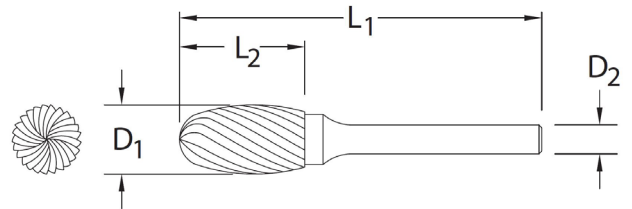

Inox E, TRE, SE - Oval Shape (Tropfenform, Ovale, Gota)

Tool	Cutting Diameter D1	Length of Cut L2	Shank Diameter D2	Overall Length L1	Cut - Inox Part No.
SE-2M	8	13	6	58	GT5300-INOX
SE-3M	10	16	6	60	GT5500-INOX
SE-5M	12	22	6	67	GT5700-INOX

INOX RANGE (INOX SERIE, GAMME INOX, GAMA INOXIDABLE)

F, RBF, SF

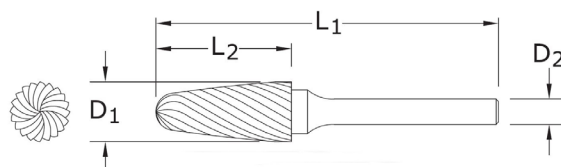

Inox F, RBF, SF - Ball Nosed Tree Shape (Rundbogenform, Ogive bout rond, Ojival esférica)

Tool	Cutting Diameter D1	Length of Cut L2	Shank Diameter D2	Overall Length L1	Cut - Inox Part No.
SF-42M	3	13	3	38	GT9200-INOX
SF-51M	6	13	3	45	GT9240-INOX
SF-1M	6	16	6	50	GT9400-INOX
SF-2M	8	19	6	65	GT9500-INOX
SF-3M	10	19	6	65	GT9600-INOX
SF-5M	12	25	6	70	GT9700-INOX

INOX RANGE (INOX SERIE, GAMME INOX, GAMA INOXIDABLE)

G, SPG, SG

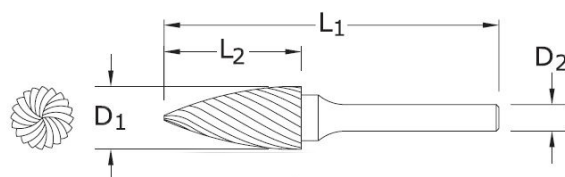

Inox G, SPG, SG - Pointed Tree Shape (Spitzbogenform, Ogive, Ojival)

Tool	Cutting Diameter D1	Length of Cut L2	Shank Diameter D2	Overall Length L1	Cut - Inox Part No.
SG-1M	6	16	6	50	GT6400-INOX
SG-2M	8	19	6	65	GT6450-INOX
SG-3M	10	19	6	65	GT6500-INOX
SG-5M	12	25	6	70	GT6800-INOX



Wear Eye Protection!



Wear Hearing Protection!



Observe the recommended rotational speed, especially when using burs with long shanks!



Wear Protective Gloves

INOX RANGE (INOX SERIE, GAMME INOX, GAMA INOXIDABLE)

H, SH

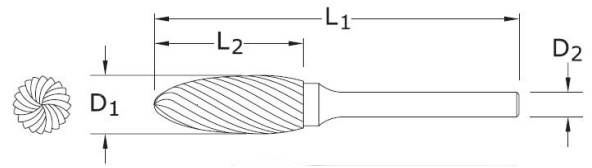

Inox H, SH - Flame Shape (Flammenform, Flamme, Llama)

Tool	Cutting Diameter D1	Length of Cut L2	Shank Diameter D2	Overall Length L1	Cut - Inox Part No.
SH-2M	8	19	6	65	GT5550-INOX
SH-3M	10	19	6	65	GT5555-INOX
SH-5M	12	32	6	77	GT5600-INOX

INOX RANGE (INOX SERIE, GAMME INOX, GAMA INOXIDABLE)

L, KEL, SL

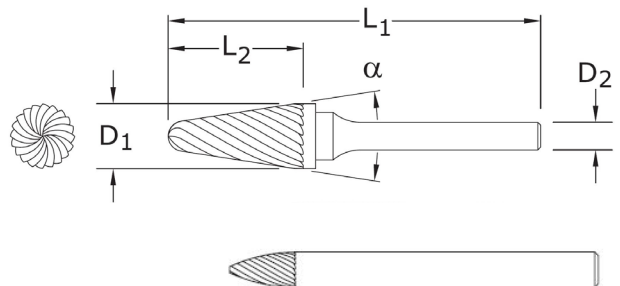

Inox L, KEL, SL - Ball Nosed Cone Shape (Rundkegelform, Conique bout rond, Cilindro cono esférico)

Tool	Cutting Diameter D1	Length of Cut L2	Shank Diameter D2	Overall Length L1	Included Angle a	Cut - Inox Part No.
SL-2M	8	22	6	69	14°	GT4500-INOX
-	10	19	6	65	14°	GT4600-INOX
SL-4M	12	30	6	75	14°	GT4700-INOX

INOX RANGE SETS

(INOX SERIE- SETS, GAMME INOX - SETS, GAMA INOXIDABLE - SETS)

Features & Benefits

FEATURES

Compact
Versatile assortment

BENEFITS

Easy to carry
Ideal for demonstrations, samplings
or special promotions



Line	Description Type	Type	Contents	Cut - Inox Part No.
Sets	BUR5 INOX	5pcs INOX CUT	GT1700-1-INOX; GT3700-1-INOX; GT9700-INOX; GT6800-INOX;GT4700-INOX	GGB KIT16
Sets	BUR5 STEEL	5pcs INOX CUT	GT1600-INOX; GT3600-INOX; GT7600-INOX; GT9600-INOX; GT4600-INOX	GGBKIT38

INOX RANGE SPEED GUIDE

(INOX SERIE- DREHZAHLECHNER, GAMME INOX - GUIDE DE VITESSES , GAMA INOXIDABLE - GUÍA DE VELOCIDADES)

MATERIAL GROUPS	N/mm2	B.S	EN	DIN
Free Machining	<850	303 S21, 416 S37	EN56 EN60	X100CrNiS189; X12CrMoS17
Austenitic	<850	304 S15, 321 S17, 316S, 320 S12	EN80, EN58+C EN58J, 316	X5CrNi189; X10CrNiMoTi1810
Ferritic; Austenitic & Martensitic	<1000	317 S16, 316 S16	EB58 b,e,j,t Duplex alloys	XbCrNiMo275; X4CrNiMoN6257

INOX	Burr Head Ø	Maximum Operating Speed	Speed Range	Suggested Air Tools
	3mm (1/8")	100,000	60,000 - 80,000	SP75R / ST100
	6mm (1/4")	65,000	30,000 - 45,000	SD45LR / S50
	10mm (3/8")	55,000	19,000 - 30,000	SD30LR / SD37LR
	12mm (1/2")	35,000	15,000 - 22,000	SMD25LR-CA / SM25LR-CA

Recommended Speeds are based on standard shank length of 45mm / (1-3/4") max overhang of 10mm (3/8")

Front & Rear Exhaust options available for certain models. Refer to ATA Air tool catalogue.



Wear Eye Protection!



Wear Hearing Protection!



Observe the recommended rotational speed, especially when using burs with long shanks!



Wear Protective Gloves



Steel Range

Steel Serie

Gamme Acier

Gama de acero

Garryson® STEEL RANGE (STEEL SERIE, GAMME ACIER, GAMA DE ACERO)

Garryson Steel Range has a specially designed geometry to suit growing market demands for steel and cast steel applications. This is a cost effective alternative to standard solutions due to a greater rate of stock removal.

Features & Benefits

- Specifically developed geometry - Increasing machining output on Steel components compared to cuts 2; 5 & 6
- Aggressive cutting form - producing large chips with increased stock removal
- Specifically engineered steel cutting geometry - generating lower heat at cutting edge
- CNC Machined - high consistent quality
- Combination of ATA air tool with Steel cut geometry - gives a guaranteed smoother grinding operation
- Manufactured to strict quality control standards - Incorporates 100% inspection of brazed joints



Wear Eye Protection!



Wear Hearing Protection!



Observe the recommended rotational speed, especially when using burs with long shanks!



Wear Protective Gloves

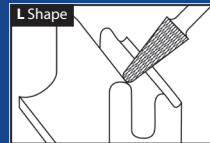
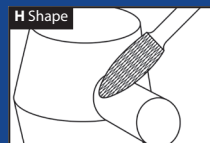
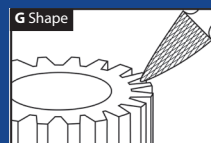
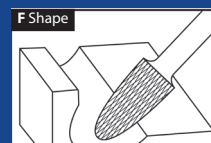
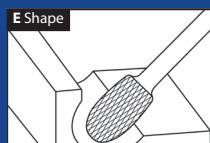
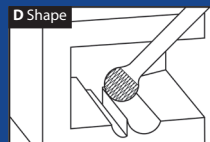
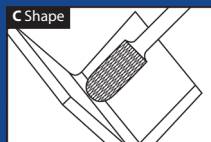
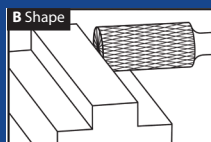
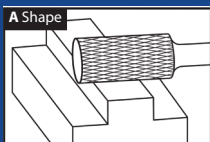

STEEL RANGE (STEEL SERIE, GAMME ACIER, GAMA DE ACERO)

A, ZYA, SA

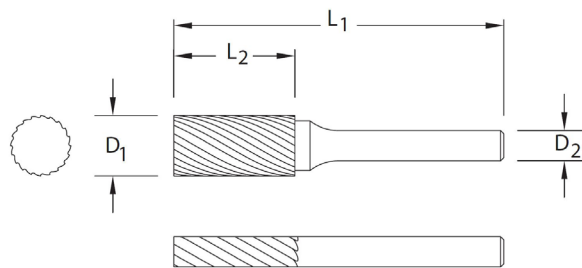

Steel A, ZYA, SA - Cylinder without Endcut (Zylinder ohne Stirverzahnung, cylindrique bout plat, Cilindro sin corte final)

Tool	Cutting Diameter D1	Length of Cut L2	Shank Diameter D2	Overall Length L1	Cut - Steel Part No.
SA-1M	6	19	6	50	GT1400-STEEL
SA-2M	8	19	6	65	GT1500-STEEL
SA-3M	10	19	6	65	GT1600-STEEL
SA-5M	12	25	6	70	GT1700-1-STEEL

STEEL RANGE (STEEL SERIE, GAMME ACIER, GAMA DE ACERO)

B, ZYAS, SB

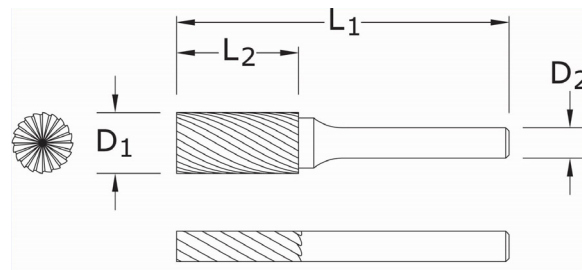

Steel B, ZYAS, SB - Cylinder with Endcut (Zylinderform - Mit Stirverzahnung, Cylindre - coupe en bout, Cilindro - con dentado frontal)

Tool	Cutting Diameter D1	Length of Cut L2	Shank Diameter D2	Overall Length L1	Cut - Steel Part No.
SB-1M	6	19	6	50	GT1402-STEEL
SB-2M	8	19	6	65	GT1502-STEEL
SB-3M	10	19	6	65	GT1602-STEEL
SB-5M	12	25	6	70	GT1702-1-STEEL

STEEL RANGE (STEEL SERIE, GAMME ACIER, GAMA DE ACERO)

C, WRC, SC

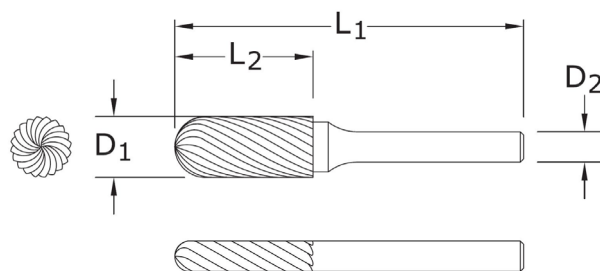

Steel C, WRC, SC - Ball Nosed Cylinder (Walzenrundform, Cylindrique bout rond, Cilindro esférico)

Tool	Cutting Diameter D1	Length of Cut L2	Shank Diameter D2	Overall Length L1	Cut - Steel Part No.
SC-1M	6	19	6	50	GT3400-STEEL
SC-2M	8	19	6	65	GT3500-STEEL
SC-3M	10	19	6	65	GT3600-STEEL
SC-5M	12	25	6	70	GT3700-1-STEEL

STEEL RANGE (STEEL SERIE, GAMME ACIER, GAMA DE ACERO)

D, KUD, SD

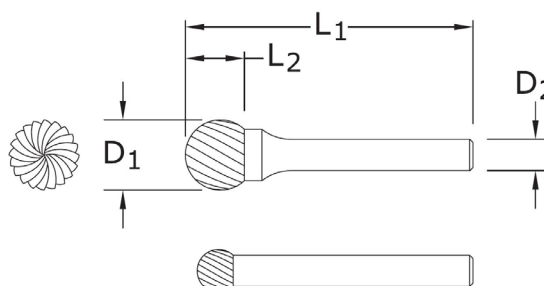

Steel D, KUD, SD - Ball Shape (Tropfenform, Ovale, Gota)

Tool	Cutting Diameter D1	Length of Cut L2	Shank Diameter D2	Overall Length L1	Cut - Steel Part No.
SD-1M	6	5.4	6	50	GT7400-STEEL
SD-2M	8	7.2	6	52	GT7500-STEEL
SD-3M	10	9	6	53	GT7600-STEEL
SD-5M	12	10.8	6	55	GT7700-STEEL

STEEL RANGE (STEEL SERIE, GAMME ACIER, GAMA DE ACERO)

E, TRE, SE

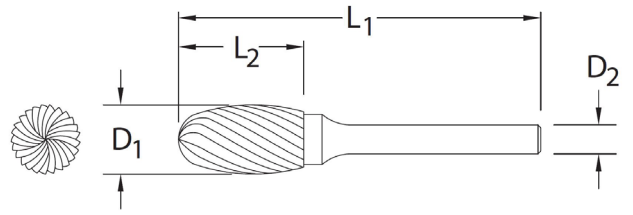

Steel E, TRE, SE - Oval Shape (Tropfenform, Ovale, Gota)

Tool	Cutting Diameter D1	Length of Cut L2	Shank Diameter D2	Overall Length L1	Cut - Steel Part No.
SE-5M	12	22	6	67	GT5700-STEEL

STEEL RANGE (STEEL SERIE, GAMME ACIER, GAMA DE ACERO)

F, RBF, SF

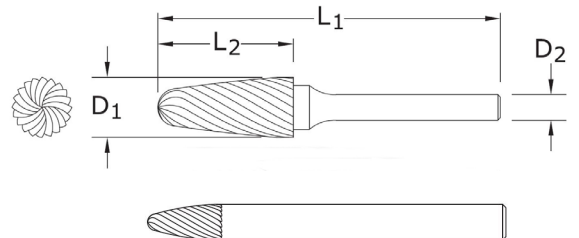

Steel F, RBF, SF - Ball Nosed Tree Shape (Rundbogenform, Ogive bout rond, Ojival esférica)

Tool	Cutting Diameter D1	Length of Cut L2	Shank Diameter D2	Overall Length L1	Cut - Steel Part No.
SF-1M	6	16	6	50	GT9400-STEEL
SF-2M	8	19	6	65	GT9500-STEEL
SF-3M	10	19	6	65	GT9600-STEEL
SF-5M	12	25	6	70	GT9700-STEEL



Wear Eye Protection!



Wear Hearing Protection!



Observe the recommended rotational speed, especially when using burs with long shanks!



Wear Protective Gloves

STEEL RANGE (STEEL SERIE, GAMME ACIER, GAMA DE ACERO)

G, SPG, SG

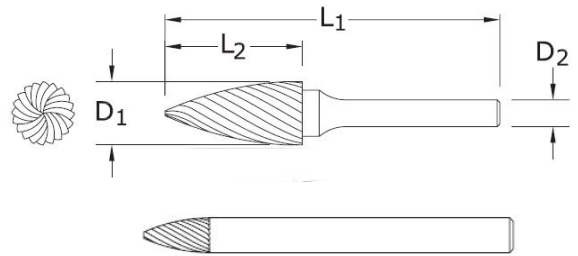

Steel G, SPG, SG - Pointed Tree Shape (Flammenform, Flamme, Llama)

Tool	Cutting Diameter D1	Length of Cut L2	Shank Diameter D2	Overall Length L1	Cut - Steel Part No.
SG-1M	6	16	6	50	GT6400-STEEL
SG-2M	8	19	6	65	GT6450-STEEL
SG-3M	10	19	6	65	GT6500-STEEL
SG-5M	12	25	6	70	GT6800-STEEL

STEEL RANGE (STEEL SERIE, GAMME ACIER, GAMA DE ACERO)

H, SH

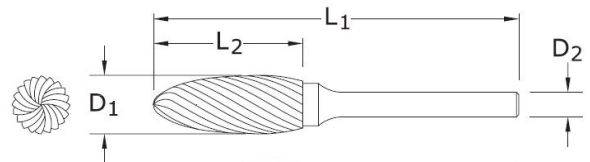

Steel H, SH - Flame Shape (Flammenform, Flamme, Llama)

Tool	Cutting Diameter D1	Length of Cut L2	Shank Diameter D2	Overall Length L1	Cut - Steel Part No.
SH-2M	8	19	6	65	GT5550-STEEL
SH-5M	12	32	6	77	GT5600-STEEL

STEEL RANGE (STEEL SERIE, GAMME ACIER, GAMA DE ACERO)

L, KEL, SL

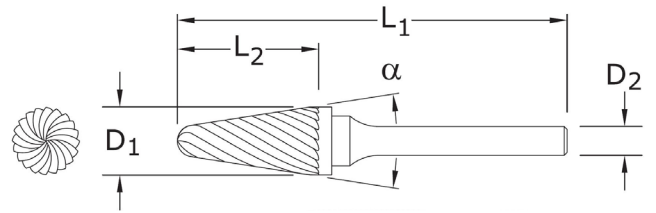

STEEL L, KEL, SL - Ball Nosed Cone Shape (Rundkegelform, Conique bout rond, Cilindro cono esférico)

Tool	Cutting Diameter D1	Length of Cut L2	Shank Diameter D2	Overall Length L1	Included Angle a	Cut - Steel Part No.
-	10	19	6	65	14°	GT4600-STEEL
SL-3M	10	27	6	75	14°	GT4600-1-STEEL
SL-4M	12	30	6	75	14°	GT4700-STEEL

STEEL RANGE SETS

(STEEL SERIE - SETS, GAMME ACIER - SETS, GAMA DE ACERO - SETS)

Features & Benefits

FEATURES

Compact
Versatile assortment

BENEFITS

Easy to carry
Ideal for demonstrations, samplings
or special promotions



Line	Description Type	Type	Contents	Cut - Steel Part No.
Sets	BUR5 STEEL	5pcs STEEL CUT	GT1702-1-STEEL; GT3700-1-STEEL; GT9700-STEEL; GT6800-STEEL; GT4700-STEEL	GGBKIT17
Sets	BUR5 STEEL	5pcs STEEL CUT	GT1602-STEEL; GT3600-STEEL; GT7600-STEEL; GT9600-STEEL; GT4600-1-STEEL	GGBKIT37

STEEL RANGE SPEED GUIDE

(STEEL SERIE- DREHZAHLECHNER, GAMME ACIER - GUIDE DE VITESSES, GAMA DE ACERO - GUÍA DE VELOCIDADES)

STEEL CONDITION	N/mm2	Material Types
Non Hardened or treated Steel	<1200	Construction steels; Structural steels; Carbon steels, Tool steels
Hardened or treated Steel	>1200	Alloy steel; Hardened and Tempered steel

STEEL	Burr Head Ø	Maximum Operating Speed	Speed Range	Suggested Air Tools
	3mm (1/8")	100,000	60,000 - 80,000	SP75R / ST100
	6mm (1/4")	65,000	45,000 - 60,000	SD45LR / S50
	10mm (3/8")	55,000	30,000 - 40,000	SD30LR / SD37LR
	12mm (1/2")	35,000	22,000 - 30,000	SMD25LR-CA / SM25LR-CA

Recommended Speeds are based on standard shank length of 45mm / (1-3/4") max overhang of 10mm (3/8")

Front & Rear Exhaust options available for certain models. Refer to ATA Air tool catalogue.

Garryson®



Base Metal Range

Metric



Garryson® BM RANGE

Introducing the new Base Metal Bur range from ATA.

Designed specifically for general deburring applications on metals less than 250 HB*.

The geometry has been specifically designed for use on Low Carbon Steels, Copper and Brass materials.

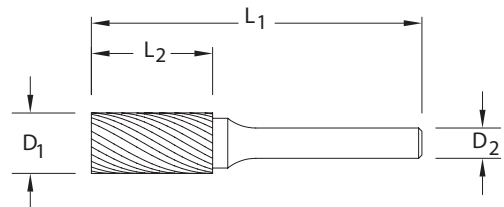

Features & Benefits:

Advanced cutting geometry

- Allowing rapid stock removal
- Increasing production output
- Resulting in a smoother operation
- Breaking down the material removed efficiently

D1	Cutting Diameter
L2	Length of Cut
D2	Shank Diameter
L1	Overall Length

CNC Machined

- High consistent quality

Combination of an ATA air tool with a Base Metal geometry –

- Delivering a guaranteed smoother grinding operation
- Maximises productivity

*Hardness Brinell

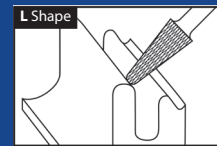
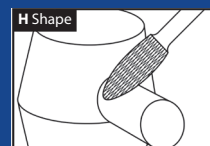
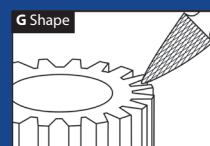
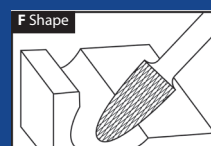
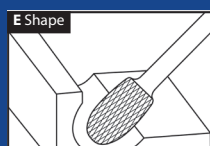
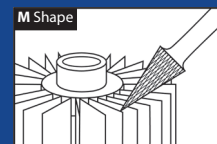
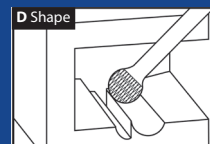
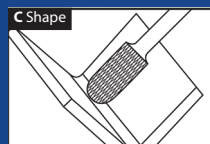
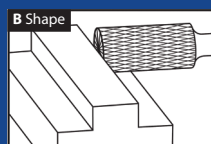
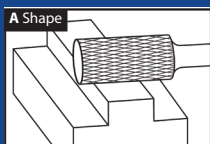

SHAPE A, ZYA, SA



Cylinder without Endcut - Shape SA,

ZYA, SA Tool	Cutting Diameter D1	Length of Cut L2	Shank Diameter D2	Overall Length L1	Part No.
SA-2M	8.0	19.0	6.0	65	GT1500D-BM
SA-3M	10.0	19.0	6.0	65	GT1600D-BM
SA-5M	12.0	25.0	6.0	70	GT1700D-1-BM

SHAPE B, ZYAS, SB



Cylinder with Endcut - Shape B, ZYAS,

SB Tool	Cutting Diameter D1	Length of Cut L2	Shank Diameter D2	Overall Length L1	Part No.
SB-2M	8.0	19.0	6.0	65	GT1502D-BM
SB-3M	10.0	19.0	6.0	65	GT1602D-BM
SB-5M	12.0	25.0	6.0	70	GT1702D-1-BM

SHAPE C, WRC, SC



Ball Nosed Cylinder - Shape C, WRC,

SC Tool	Cutting Diameter D1	Length of Cut L2	Shank Diameter D2	Overall Length L1	Part No.
SC-2M	8.0	19.0	6.0	65	GT3500D-BM
SC-3M	10.0	19.0	6.0	65	GT3600D-BM
	12.0	19.0	6.0	65	GT3700D-BM
SC-5M	12.0	25.0	6.0	70	GT3700D-1-BM



Wear Eye Protection!



Wear Hearing Protection!



Observe the recommended rotational speed, especially when using burs with long shanks!



Wear Protective Gloves



Wear Protective Mask

SHAPE G, SPG, SG



Pointed Tree- Shape G, SPG, SG

Tool	Cutting Diameter D1	Length of Cut L2	Shank Diameter D2	Overall Length L1	Part No.
SG-2M	8.0	19.0	6.0	65	GT6450D-BM
SG-3M	10.0	19.0	6.0	65	GT6500D-BM
SG-5M	12.0	25.0	6.0	70	GT6800D-BM

SHAPE H, SH



Flame - Shape H, SH

Tool	Cutting Diameter D1	Length of Cut L2	Shank Diameter D2	Overall Length L1	Part No.
SH-5M	12.0	32.0	6.0	77	GT5600D-BM

SHAPE L, KEL, SL



Ball Nosed Cone- Shape L, KEL, SL

Tool	Cutting Diameter D1	Length of Cut L2	Shank Diameter D2	Overall Length L1	Part No.
SL-2M	8.0	22.0	6.0	69	GT4500D-BM
	10.0	19.0	6.0	65	GT4600D-BM
SL-3M	10.0	27.0	6.0	75	GT4600D-1-BM
SL-4M	12.0	30.0	6.0	75	GT4700D-BM



Wear Eye Protection!



Wear Hearing Protection!



Observe the recommended rotational speed, especially when using burs with long shanks!



Wear Protective Gloves



Wear Protective Mask

SHAPE M,SKM,SM



Cone- Shape M, SKM, SM

Tool	Cutting Diameter D1	Length of Cut L2	Shank Diameter D2	Overall Length L1	Part No.
SM-4M	10.0	16.0	6.0	65	GT2600D-BM
SM-5M	12.0	25.0	6.0	70	GT2700D-1-BM

BM RANGE SPEED GUIDE

	Material Groups	HB*	B.S	EN	DIN
Steel	Magnetic Soft	<120	230M07, 050A12	EN1, EN2 Leadloy	RFe60
	Structural case carburising	<200	060A35, 080M40, 4360-50B	EN3A, 4,6,7,8 32	st37-2, 16MnCr5, St50-2
Cast Iron	Lameller graphite	<150	grade 150, grade 400	Grey cast iron soft	GG10, GG40
	Nodular graphite, malleable	<200	420/12, P440/7, 700/2, 30g/72	S.G. iron Mehanite	GGG40, GGG70, GTS45-
Brass, Copper, Bronze	Unalloyed	<100	C101	Commercially Pure	E-Cu57, SE-Cu
	β - Brass, Bronze	<200	CZ120, CZ109, PB104	2.1030, 2.1080	CuZn39Pb2, CuZn40,
	Y - Brass	<200	CZ108, CZ106		CuZn37, CuZn28

Head Diameter	6mm	8mm	10mm	12mm	Suggested Air Tool Ranges
Max. RPM	65,000	60,000	55,000	35,000	
Steel	35,000 - 45,000	30,000 - 40,000	22,500 - 35,000	20,500 - 30,000	S, SD, SM & SMD Die Grinder Ranges*
Cast Iron	22,500 - 45,000	20,000 - 40,000	15,000 - 35,000	11,000 - 30,000	
Brass, Copper, Bronze	22,500 - 45,000	20,000 - 40,000	15,000 - 35,000	11,000 - 30,000	

*Hardness Brinell

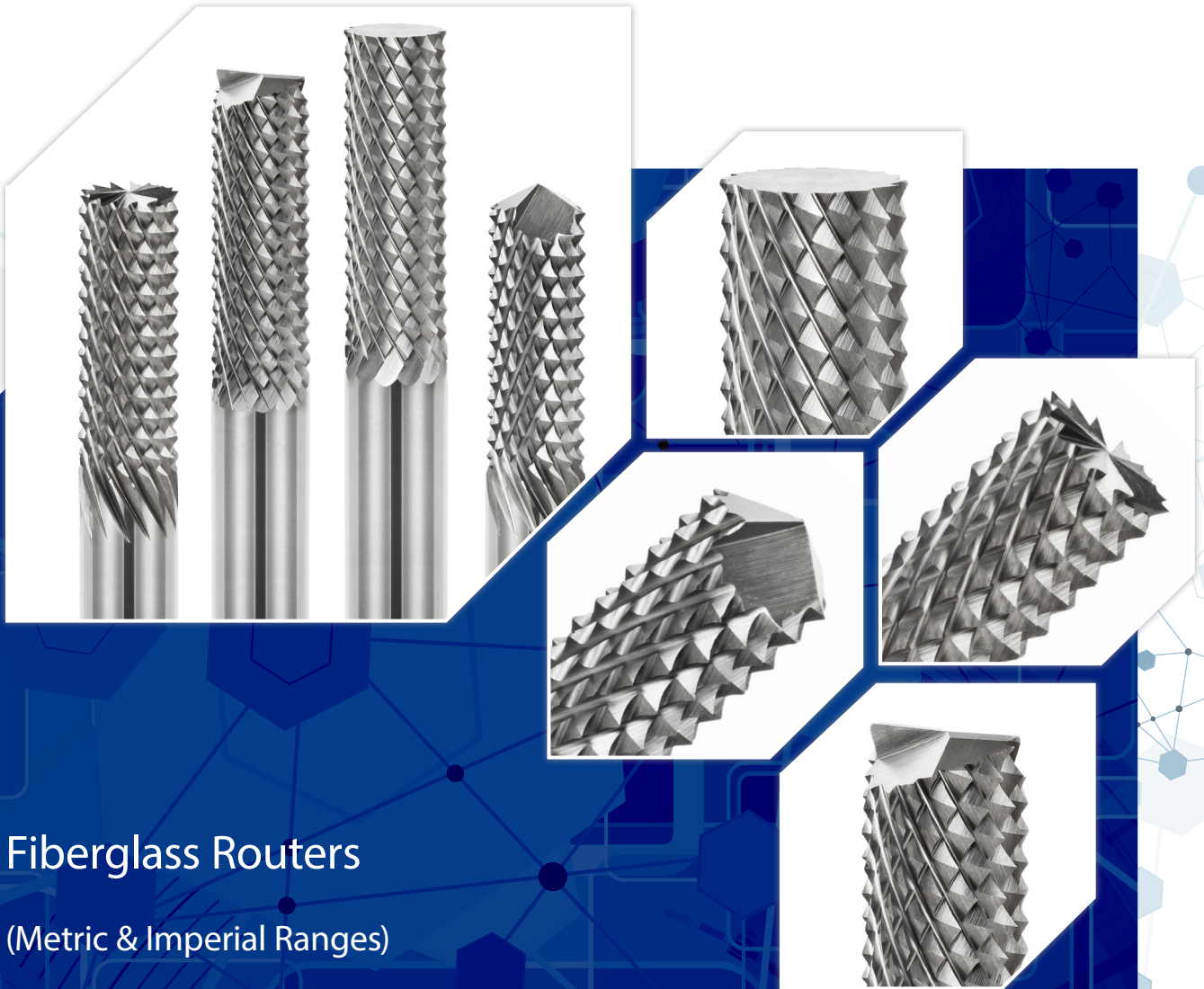

Fiberglass Routers

(Metric & Imperial Ranges)

Konturenfräser - *Metrisches und Imperiales Sortiment*

Fraises à détourer pour fibre de verre - *Dimensions métriques et impériales*

Fresas para fibra de vidrio - *Sistemas métrico e imperial*

Garryson® FIBERGLASS ROUTERS

(KONTURENFRÄSER, FRAISES À DÉTOURER POUR FIBRE DE VERRE, FRESAS PARA FIBRA DE VIDRIO)

Features

- Special cut style

Benefits

- Best for roughing and contouring composite
- Can be used with hand-held tools or CNC machines
- Can be used on various materials, from large fiberglass panels to small parts made of composite

METRIC RANGE

(METRISCHES SORTIMENT, DIMENSION MÉTRIQUES , SISTEMAS MÉTRICO)

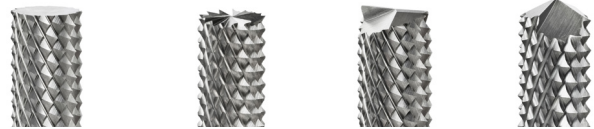
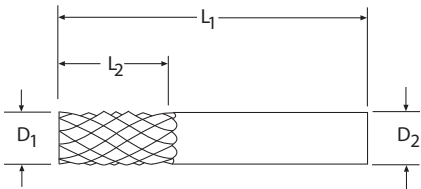

Cutting Ø D1	Length of Cut L2	Shank Ø D2	Overall Length L1	No End Cut	Bur Style	Endmill	Drill Point
3mm	12mm	3mm	38mm	G26011810	G26111810	G26211810	G26311810
4mm	16mm	4mm	50mm	G26015750	G26115750	G26215750	G26315750
6mm	19mm	6mm	50mm	G26023620	G26123620	G26223620	G26323620
6mm	19mm	6mm	63mm	G26023620L	G26123620L	G26223620L	G26323620L
8mm	25mm	8mm	63mm	G26031500	G26131500	G26231500	G26331500
10mm	25mm	10mm	75mm	G26039370	G26139370	G26239370	G26339370
12mm	25mm	12mm	75mm	G26047240	G26147240	G26247240	G26347240

NO END CUT	Used for profile applications
BUR STYLE	Used for profiling and slotting application
ENDMILL	Used for plunging, slotting and profiling applications were a square corner is required
DRILL POINT	Used for plunging into application prior to starting routing operation

Scan to visit our website



Recommendations

- The routers are recommended for use on phenolics, fiberglass and hard non-metallic materials
- For best results, FGRs should be rigidly mounted in accurate collet chucks

Applications

- Trimming
- Routing
- Pocketing

IMPERIAL RANGE

(IMPERIALES SORTIMENT, DIMENSION IMPÉRIALES, SISTEMAS IMPERIAL)

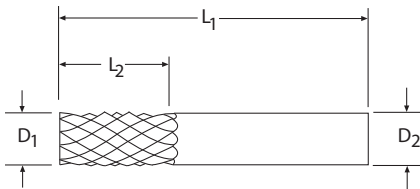

Cutting Ø D1	Length of Cut L2	Shank Ø D2	Overall Length L1	No End Cut	Bur Style	Endmill	Drill Point
1/16"	3/16"	1/8"	1-1/2"	G26006250	-	G26206250	-
3/32"	3/8"	1/8"	1-1/2"	G26009370	-	G26209370	G26309370
1/8"	1/2"	1/8"	1-1/2"	G26012500	G26112500	G26212500	G26312500
3/16"	5/8"	3/16"	2"	G26018750	G26118750	G26218750	G26318750
1/4"	3/4"	1/4"	2"	G26025000	G26125000	G26225000	G26325000
1/4"	3/4"	1/4"	2-1/2"	G26025000L	G26125000L	G26225000L	G26325000L
3/8"	1"	3/8"	2-1/2"	G26037500	G26137500	G26237500	G26337500
1/2"	1"	1/2"	3"	G26050000	G26150000	G26250000	G26350000

NO END CUT	Used for profile applications
BUR STYLE	Used for profiling and slotting application
ENDMILL	Used for plunging, slotting and profiling applications were a square corner is required
DRILL POINT	Used for plunging into application prior to starting routing operation



Wear Eye Protection!



Wear Hearing Protection!



Observe the recommended rotational speed, especially when using burs with long shanks!



Wear Protective Gloves



Wear Protective Mask

Garryson®



Bur Sets

Frässtift-Sets

Kits de fraises

Juegos de fresas rotativas



Garryson® BUR SETS

(FRÄSSTIFT-SETS, KITS DE FRAISES, JUEGOS DE FRESAS ROTATIVAS)

ATA has selected an assortment of the most popular burs for use in general application. These sets are presented in robust packaging that is:

- Easy to carry
- Compact
- Recyclable

Ideal for:

- Demonstrations
- Samplings
- Special Promotions

The following sets are all universal double cut sets:

- Designed for general application
- Reduced chip size
- Offers good control
- Industries - applicable to all industries

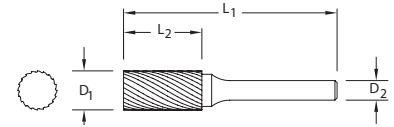

D1	Cutting Diameter
L2	Length of Cut
D2	Shank Diameter
L1	Overall Length

GGBKIT28	GGBKIT29	GGBKIT34	GGBKIT36
GGBKIT30	GGBKIT31	GGBKIT35	

Double Cut - 5 Piece Set

(Kreuzverzahnung - Set mit 5 Stück, Double coupe - Kit de 5 pièces, Doble corte - Juego de 5 unidades)

GGBKIT28

CONTENTS

- 5 piece selection of established shaped burs
- 10mm and 12mm cut diameters
- 6mm shanks



Description	Cut Ø D1	Length of Cut L2	Shank Ø D2	Overall Length L1	Incl. Angle	Garryson No.
Cylinder with endcut	10	19	6	65		GT1602D
Ball nosed cylinder	12	25	6	70		GT3700D-1
Ball nosed tree	12	25	6	70		GT9700D
Pointed tree	10	19	6	65		GT6500D
Ball nosed cone	12	30	6	75	14°	GT4700D

Double Cut - 5 Piece Set (9.6mm)

(Kreuzverzahnung - Set mit 5 Stück, Double coupe - Kit de 5 pièces, Doble corte - Juego de 5 unidades)

GGBKIT36

CONTENTS

- 5 piece selection of established shaped burs
- 9.6mm cut diameters
- 6mm shanks



Description	Cut Ø D1	Length of Cut L2	Shank Ø D2	Overall Length L1	Incl. Angle	Garryson No.
Cylinder with endcut	10	19	6	65		GT1602D
Ball nosed cylinder	10	19	6	65		GT3600D
Ball	10	9	6	53		GT7600D
Ball Nosed tree	10	19	6	65		GT9600D
Ball nosed cone	10	27	6	75	14°	GT4600D-1

Double Cut - 5 Piece Set

(Kreuzverzahnung - Set mit 5 Stück, Double coupe - Kit de 5 pièces, Doble corte - Juego de 5 unidades)

GGBKIT31



CONTENTS

- 5 piece selection of coated burs
- 10mm & 12mm cut diameters
- 6mm shanks

Description	Cut Ø D1	Length of Cut L2	Shank Ø D2	Overall Length L1	Incl. Angle	Garryson No.
Cylinder with endcut	10	19	6	65		GCZ1602D
Ball nosed cylinder	12	25	6	70		GCZ3700D-1
Ball nosed tree	12	25	6	70		GCZ9700D
Pointed tree	10	19	6	65		GCZ6500D
Ball nosed cone	12	30	6	75	14°	GCZ4700D

Double Cut - 10 Piece Set

(Kreuzverzahnung - Set mit 10 Stück, Double coupe - Kit de 10 pièces, Doble corte - Juego de 10 unidades)

GGBKIT30



CONTENTS

- 10 piece selection of established shaped burs
- 10mm and 12mm cut diameters
- 6mm shanks

Description	Cut Ø D1	Length of Cut L2	Shank Ø D2	Overall Length L1	Incl. Angle	Garryson No.
Cylinder with endcut	10	19	6	65		GT1602D
Cylinder with endcut	12	25	6	70		GT1702D-1
Ball nosed cylinder	10	19	6	65		GT3600D
Ball nosed cylinder	12	25	6	70		GT3700D-1
Ball	12	10.8	6	55		GT7700D
Oval	10	16	6	60		GT5500D
Ball nosed tree	12	25	6	70		GT9700D
Tree	10	19	6	65		GT6500D
Tree	12	25	6	70		GT6800D
Ball nosed cone	12	30	6	75	14°	GT4700D



Wear Eye Protection!



Wear Hearing Protection!



Observe the recommended rotational speed, especially when using burs with long shanks!



Wear Protective Gloves



Wear Protective Mask

Double Cut - 5 Piece Set

(Kreuzverzahnung - Set mit 5 Stück, Double coupe - Kit de 5 pièces, Doble corte - Juego de 5 unidades)

GGBKIT29



CONTENTS

- 5 piece selection of established burs
- 12mm cut diameters
- 6mm shanks

Description	Cut Ø D1	Length of Cut L2	Shank Ø D2	Overall Length L1	Incl. Angle	Garryson No.
Cylinder with endcut	12	25	6	70		GT1702D-1
Ball nosed cylinder	12	25	6	70		GT3700D-1
Ball	12	10.8	6	55		GT7700D
Ball nosed tree	12	25	6	70		GT9700D
Cone	12	25	6	70	28°	GT2700D-1

Double Cut Miniature - 10 Piece Set

(Kreuzverzahnung Miniatur - Set mit 10 Stück, Double coupe miniature - Kit de 10 pièces, Doble corte Miniatura - Juego de 10 unidades)

GGBKIT34



CONTENTS

- 10 piece selection of established burs
- 3mm cut diameters
- 3mm shanks

Description	Cut Ø D1	Length of Cut L2	Shank Ø D2	Overall Length L1	Incl. Angle	Garryson No.
Cylinder without endcut	3	13	3	38		GT1200D
Cylinder with endcut	3	13	3	38		GT1202D
Ball nosed cylinder	3	13	3	38		GT3200D
Ball	3	2.7	3	38		GT7200D
Oval	3	6	3	38		GT5220D
Ball nosed tree	3	13	3	38		GT9200D
Tree	3	13	3	38		GT6200D
Flame	3	8	3	38		GT5200D
Ball nosed cone	3	9.5	3	38	8°	GT4210D
Cone	3	11	3	38	14°	GT2200D



Wear Eye Protection!



Wear Hearing Protection!



Observe the recommended rotational speed, especially when using burs with long shanks!



Wear Protective Gloves



Wear Protective Mask

Double Cut - 40 Piece Display Case

(Kreuzverzahnung - Schaukasten mit 40 Stück, Double coupe – Présentoir de 40 pièces, Doble corte -Expositor de 40 unidades)

GGBKIT35

40 Piece display case showcases the wider bur offering.

- Counter top display
- Low maintenance
- Heavy duty packaging
- Secure product
- Maximise retail space
- 100% recyclable

Contents include:

- 6mm, 8mm, 10mm & 12mm diameter
- 6mm shanks
- Five shape configurations



Description	Cut Ø D1	Length of Cut L2	Shank Ø D2	Overall Length L1	Incl. Angle	Garryson No.
Cylinder with endcut	6	19	6	50		GT1402D
Cylinder with endcut	8	19	6	65		GT1502D
Cylinder with endcut	10	19	6	65		GT1602D
Cylinder with endcut	12	25	6	70		GT1702D-1
Ball nosed cylinder	6	19	6	50		GT3400D
Ball nosed cylinder	8	19	6	65		GT3500D
Ball nosed cylinder	10	19	6	65		GT3600D
Ball nosed cylinder	12	25	6	70		GT3700D-1
Ball nosed tree	6	16	6	50		GT9400D
Ball nosed tree	8	20	6	65		GT9500D
Ball nosed tree	10	19	6	65		GT9600D
Ball nosed tree	12	25	6	70		GT9700D
Pointed tree	6	16	6	50		GT6400D
Pointed tree	8	19	6	65		GT6450D
Pointed tree	10	19	6	65		GT6500D
Pointed tree	12	25	6	70		GT6800D
Ball nosed cone	6	16	6	50	14°	GT4400D
Ball nosed cone	8	22	6	69	14°	GT4500D
Ball nosed cone	10	27	6	75	14°	GT4600D-1
Ball nosed cone	12	30	6	75	14°	GT4700D

Aluminium Cut - 5 Piece Set

(Aluminium - Set mit 5 Stück, Coupe Aluminium - Kit de 5 pièces, Aluminio - Juego de 5 unidades)

GGBKIT33

CONTENTS

- 5 piece selection of established shaped burs
- 12mm cut diameter
- 6mm shanks
- Aluminium cut - maximum stock removal
- Aluminium cut - maximum stock removal on non-ferrous and plastics materials



Description	Cut Ø D1	Length of Cut L2	Shank Ø D2	Overall Length L1	Incl. Angle	Garryson No.
Cylinder with endcut	12	25	6	70		GCZTA170
Ball nosed cylinder	12	25	6	70		GCZTA370
Ball	12	10.8	6	55		GCZTA770
Ball nosed tree	12	25	6	70		GCZTA970
Ball nosed cone	12	32	6	75	14°	GCZTA470

D-Max Range - 5 Piece Set

(D-max Serie - Set mit 5 Stück, Gamme D-max - Kit de 5 pièces, Gama D-max - Juego de 5 unidades)

GGBKIT32

CONTENTS

- 5 piece selection of established shaped burs
- 12mm cut diameter
- 6mm shanks

BENEFITS

- D-Max - maximum stock removal
- Industries - foundry and ship building steel applications



Description	Cut Ø D1	Length of Cut L2	Shank Ø D2	Overall Length L1	Incl. Angle	Garryson No.
Cylinder with endcut	12	25	6	70		GTDX172-1
Ball nosed cylinder	12	25	6	70		GTDX370-1
Ball nosed tree	12	25	6	70		GTDX970
Pointed tree	12	25	6	70		GTDX680
Ball nosed cone	12	30	6	75	14°	GTDX470

AS Range Set

FEATURES

- Compact
- Versatile

BENEFITS

- Easy to carry
- Ideal for demonstrations, samplings or special promotions



Line	Description Type	Contents	Alloy Specific Part No.
Sets	10 pcs Alloy Specific Cut	GT1200-AS; GT3200-AS; GT7200-AS; GT5220-AS; GT9200-AS; GT6220-AS; GT6200-AS; GT5200-AS; GT4220-AS; GT2220-AS	GGBKIT39

Inox Range - 5 Piece Set

(Inox Serie - Set mit 5 Stück, Gamme Inox - Kit de 5 pièces, Gama inoxidable - Juego de 5 unidades)

GGBKIT16

CONTENTS

- 5 piece selection of established shaped burs
- 12mm cut diameter
- 6mm shanks

BENEFITS

- Developed cutting geometry
- High performance grinding
- Reduces heat build up on the workpiece

See the bur in action!



Description	Cut Ø D1	Length of Cut L2	Shank Ø D2	Overall Length L1	Incl. Angle	Garryson No.
Cylinder without endcut	12	25	6	70		GT1700-1-INOX
Ball nosed cylinder	12	25	6	70		GT3700-1-INOX
Ball nosed tree	12	25	6	70		GT9700-INOX
Pointed tree	12	25	6	70		GT6800-INOX
Ball nosed cone	12	30	6	75	14°	GT4700-INOX

Inox Range - 5 Piece Set (9.6mm)

(Inox Serie - Set mit 5 Stück, Gamme Inox - Kit de 5 pièces, Gama inoxidable - Juego de 5 unidades)

GGBKIT38

CONTENTS

- 5 piece selection of established shaped burs
- 9.6mm cut diameter
- 6mm shanks

BENEFITS

- Developed cutting geometry
- High performance grinding
- Reduces heat build up on the workpiece



Description	Cut Ø D1	Length of Cut L2	Shank Ø D2	Overall Length L1	Incl. Angle	Garryson No.
Cylinder without endcut	10	19	6	65		GT1600-INOX
Ball nosed cylinder	10	19	6	65		GT3600-INOX
Ball	10	9	6	53		GT7600-INOX
Ball Nosed Tree	10	19	6	65		GT9600-INOX
Ball nosed cone	10	19	6	65	14°	GT4600-INOX

Steel Range - 5 Piece Set

(Steel Serie - Kit de 5 pièces, Gamme Acier - Kit de 5 pièces, Gama de acero - Juego de 5 unidades)

GGBKIT17

CONTENTS

- 5 piece selection of most common shaped burs
- 12mm cut diameter
- 6mm shanks

BENEFITS

- Increasing machine output on steel components
- Aggressive cutting form
- Specifically engineered steel cutting geometry

See the bur
in action!



Description	Cut Ø D1	Length of Cut L2	Shank Ø D2	Overall Length L1	Incl. Angle	Garryson No.
Cylinder with endcut	12	25	6	70		GT1702-1-STEEL
Ball nosed cylinder	12	25	6	70		GT3700-1-STEEL
Ball nosed tree	12	25	6	70		GT9700-STEEL
Pointed tree	12	25	6	70		GT6800-STEEL
Ball nosed cone	12	30	6	75	14°	GT4700-STEEL

Steel Range - 5 Piece Set (9.6mm)

(Steel Serie - Kit de 5 pièces, Gamme Acier - Kit de 5 pièces, Gama de acero - Juego de 5 unidades)

GGBKIT37

CONTENTS

- 5 piece selection of most common shaped burs
- 9.6mm cut diameter
- 6mm shanks

BENEFITS

- Increasing machine output on steel components
- Aggressive cutting form
- Specifically engineered steel cutting geometry



Description	Cut Ø D1	Length of Cut L2	Shank Ø D2	Overall Length L1	Incl. Angle	Garryson No.
Cylinder with endcut	10	19	6	65		GT1602-STEEL
Ball nosed cylinder	10	19	6	65		GT3600-STEEL
Ball	10	9	6	53		GT7600-STEEL
Ball Nosed Tree	10	19	6	65		GT9600-STEEL
Ball nosed cone	10	19	6	65	14°	GT4600-1-STEEL

The Radius bur sets contain an exclusive range of multi-application burs that cover all general metal removal, thanks to the exclusive inverted curve design.

5 Piece Chamfer Application Set

(Combi-Frässtifte - Set mit 5 Stück, Fraise Combi - Kit de 5 pièces, Fresas rotativas combinadas - Juego de 5 unidades)

GGBKIT25

CONTENTS

- 12.7mm and 16mm cutting diameter
- 6mm shanks

BENEFITS

- Easy control
- Reduce downtime
- Creates smooth radius



Description	Cut Ø D1	Length of Cut L2	Shank Ø D2	Overall Length L1	Garryson No.
Double Inverted 45°	16.0	15	6	60	GKN61515-2
Radius/Cylinder with endcut	12.7	25	6	70	GBMN61225-6F
Radius/ Cylinder ball nosed	12.7	25	6	70	GCMN61225-6F
Radius/Ball nosed tree	12.7	35	6	80	GFMN61235-6F
Radius/Cylinder/Countersink 90°	12.7	28	6	73	GKMN61228-6F



Wear Eye Protection!



Wear Hearing Protection!



Observe the recommended rotational speed, especially when using burs with long shanks!



Wear Protective Gloves



Wear Protective Mask

Garryson®

10 Piece Radius Application Set

(Combi-Frässtifte - Set mit 10 Stück, Fraise Combi – Kit de 10 pièces, Fresas rotativas combinadas - Juego de 10 unidades)

GGBKIT19

See the bur
in action!



CONTENTS

- 12.7mm cut diameter
- 6mm shanks

Description	Cut Ø D1	Length of Cut L2	Shank Ø D2	Overall Length L1	Garryson No.
Radius/Cylinder	12.7	25	6	70	GAMN61225-6F
Radius/Cylinder with endcut	12.7	25	6	70	GBMN61225-6F
Radius/ Cylinder ball nosed	12.7	25	6	70	GCMN61225-2
Radius/ Cylinder ball nosed	12.7	25	6	70	GCMN61225-2F
Radius/ Cylinder ball nosed	12.7	25	6	70	GCMN61225-6F
Radius/Ball nosed tree	12.7	35	6	80	GFMN61235-6F
Radius/Tree	12.7	35	6	80	GGMN61235-6F
Radius/ Countersink 60°	12.7	31	6	76	GJMN61231-6F
Radius/Cylinder/Countersink 90°	12.7	28	6	73	GKMN61228-6F
Radius/Ball nose cone	12.7	35	6	80	GLMN61235-6F

The Combi bur sets include high performance, multi-purpose burs for the multi-application industries. Their innovative design allow for less downtime and covers multiple applications.

5 Piece Multi Purpose Set GGBKIT20

CONTENTS

- 12.7mm & 16mm cut diameter
- 6mm shanks

BENEFITS

- Better performance
- Suit complex application
- Consistent performance



Description	Cut Ø D1	Length of Cut L2	Shank Ø D2	Overall Length L1	Garryson No.
Inverted/Ball	12.7	20	6	65	GDN61220-6
Cylinder/Countersink 60°	12.7	25	6	70	GJA61225-6
Inverted/Countersink 90°	12.7	18	6	64	GKN61218-6
Double Inverted 45°	16.0	15	6	60	GKN61515-2
Double Inverted	12.7	25	6	70	GNN61225-6

10 Piece Multi Application Set GGBKIT21

CONTENTS

- 12.7mm cut diameter
- 6mm shanks



Description	Cut Ø D1	Length of Cut L2	Shank Ø D2	Overall Length L1	Garryson No.
Inverted/Cylinder endcut	12.7	25	6	70	GBN61225-6
Inverted/Ball	12.7	20	6	65	GDN61220-2
Inverted/Ball nosed tree	12.7	32	6	77	GFN61232-6
Inverted/Tree	12.7	32	6	77	GGN61232-6
Inverted/Countersink 60°	12.7	23	6	68	GJN61223-6
Cylinder/Countersink 90°	12.7	25	6	70	GKA61225-6
Inverted/Countersink 90°	12.7	18	6	64	GKN61218-6
Inverted/Ball nosed cone	12.7	32	6	77	GLN61232-6
Inverted/Cone	12.7	35	6	80	GMM61235-6
Double Inverted	12.7	25	6	70	GNN61225-6

The Corner Radius bur set has been specially designed to meet the high manufacturing standards of the Aerospace industry. The radius design at the top allows for extended tool life.

Corner Radius - 6 Piece Set

(Corner Radius - Set mit 6 Stück, Corner Radius – Kit de 6 pièces, Esquina radial - Juego de 6 unidades)

GGBKIT22

CONTENTS

- 3mm, 6mm, 8mm, 9.6mm, 12.7mm and 16mm cut diameter
- 3mm and 6mm shanks

BENEFITS

- Flute strength
- Prevents from digging
- Reduces flute chipping

See the bur in action!



Description	Cut Ø D1	Length of Cut L2	Shank Ø D2	Overall Length L1	Garryson No.
Cylinder with Radius	3.0	14	3	38	GA30314-6 RAD
Cylinder with Radius	6.0	18	6	50	GA60618-6 RAD
Cylinder with Radius	8.0	20	6	64	GA60820-6 RAD
Cylinder with Radius	9.6	19	6	64	GA61020-6 RAD
Cylinder with Radius	12.7	25	6	70	GA61225-6 RAD
Cylinder with Radius	16.0	25	6	70	GA61525-6 RAD



Wear Eye Protection!



Wear Hearing Protection!



Observe the recommended rotational speed, especially when using burs with long shanks!



Wear Protective Gloves



Wear Protective Mask

Garryson®

International Offices

t: +353 (0) 49 432 6178
f: +353 (0) 49 432 6298

e: sales@atagroup.ie
w: www.atagroup.co

ATA Tools Ltd., IDA Business & Technology Park,
Killygarry, Cavan, Co. Cavan, H12 DK46, Ireland

UK Offices

t: +44 (0) 1530 261 145
f: +44 (0) 1530 262 801

e: sales@atagarryson.com
w: www.atagroup.co

ATA Garryson Ltd., Spring Road, Ibstock,
Leicestershire, LE67 6LR, United Kingdom

US Offices

t: +1 330-928-7744
f: +1 330-849-2977

e: sales@atatools.com
w: www.atagroup.co

ATA Tools Inc., 7 Ascot Parkway,
Akron, Ohio 44223, USA

